

# NOBLELIFT

## Operation Safety and Maintenance Manual Scissor lifts

SC10H/SC12H/SC14H/SC16H/SC10E/SC12E/SC14E/SC16E/SC08HN/SC10HN/SC08EN/SC10EN

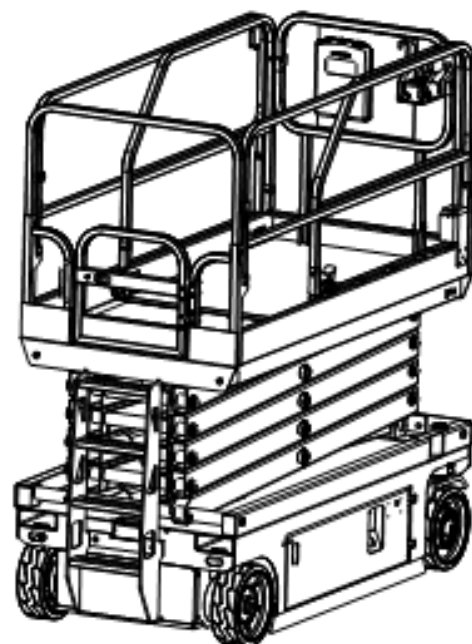

### **WARNING**

Do not use the pallet truck before reading and understanding these operating instructions.

### **NOTE:**

- Keep for future reference.

Version 07/2018

SC-SMS-003-EN

# Contents

Introduction.....	1
Symbol and Hazard Pictorials Definitions.....	4
General Safety .....	6
Personal Safety .....	8
Work Area Safety.....	9
Legend .....	18
Controls .....	19
Inspections .....	23
Specifications.....	36
Operating Instructions.....	48
Transport and Lifting Instructions .....	57
Maintenance.....	62
Schematic Diagram.....	103
Schedule 1 Fault Code .....	112
Schedule 2 Inspection and Maintenance Records .....	117

## Introduction

### Important

Read, understand and obey these safety rules and operating instructions before operating this machine. Only trained and authorized personnel shall be permitted to operate this machine. This manual should be considered a permanent part of your machine and should remain with the machine at all times. If you have any questions, contact us.

### Owners, Users and Operators:

Thank you for choosing our machine for your application. Our number one priority is user safety, which is best achieved by our joint efforts. We feel that you make a major contribution to safety if you, as the equipment users and operators:

- 1 Comply with employer, job site and governmental rules.
- 2 Read, understand and follow the instructions in this and other manuals supplied with this machine.
- 3 Use good safe work practices in a commonsense way.
- 4 Only have trained/certified operators, directed by informed and knowledgeable supervision, running the machine.

## Introduction



### **Danger**

Failure to obey the instructions and safety rules in this manual will result in death or serious injury.

### **Do Not Operate Unless:**

- You learn and practice the principles of safe machine operation contained in this operator's manual.

1 Avoid hazardous situations.

Know and understand the safety rules before going on to the next section.

2 Always perform a pre-operation inspection.

3 Always perform function tests prior to use.

4 Inspect the workplace.

5 Only use the machine as it was intended.

- You read, understand and obey the manufacturer's instructions and safety rules—safety and operator's manuals and machine decals.
- You read, understand and obey employer's safety rules and worksite regulations.
- You read, understand and obey all applicable governmental regulations.
- You are properly trained to safely operate the machine.

## Introduction

### Hazard Classification

Decals on this machine use symbols, color coding and signal words to identify the following:



Safety alert symbol—used to alert you to potential personal injury hazards. Obey all safety messages that follow this symbol to avoid possible injury or death.



Indicates a hazardous situation which, if not avoided, will result in death or serious injury.

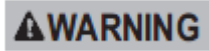

Indicates a hazardous situation which, if not avoided, could result in death or serious injury.

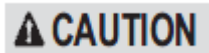

Indicates a hazardous situation which, if not avoided, could result in minor or moderate injury.



Indicates a property damage message.

























### Intended Use

This machine is intended to be used only to lift personnel, along with their tools and materials to an aerial work site.

















### Safety Sign Maintenance

Replace any missing or damaged safety signs. Keep operator safety in mind at all times. Use mild soap and water to clean safety signs. Do not use solvent-based cleaners because they may damage the safety sign material.

## Symbol and Hazard Pictorials Definitions

				
Read the operator's manual	Read the service manual	Crush hazard	Crush hazard	Collision hazard
				
Tip-over hazard	Tip-over hazard	Tip-over hazard	Tip-over hazard	Electrocution hazard
				
Electrocution hazard	Explosion hazard	Fire hazard	Burn hazard	Skin injection hazard
				
Engage safety arm	Keep away from moving parts	Keep clear of outriggers and tires	Move machine to level ground	Close chassis tray
				
Lower the platform	Do not set up where it cannot be leveled with outriggers	Maintain required clearance	Only trained maintenance personnel should access compartments	Use a piece of cardboard or paper to search for leaks

## Symbol and Hazard Pictorials Definitions

 Batteries used as counterweights	 Chock the wheels	 Release brakes	 Grounded AC 3-wire only	 Replace damaged wires and cords
 Wheel load	 Transport diagram	 Tiedown	 Lanyard anchorage points	 No smoking
 Voltage rating for power to platform	 Pressure rating for air line to platform	 Manual force	 Wind speed	
 Maximum capacity	 Outdoor		 Indoor	

## General Safety

page 32~33

602047020015

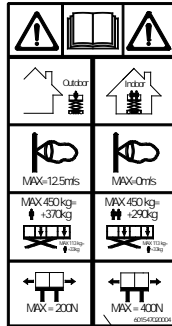

602047020014

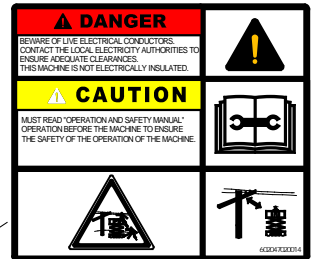

page 32~33

**SC10H**

941200300006



page 32~33

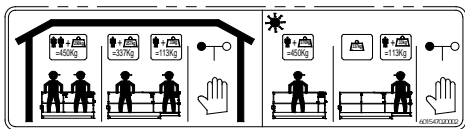

602047020028

**NOBLELIFT**

602047020031



602047020045



602047020024

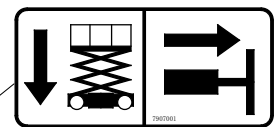

602047020046

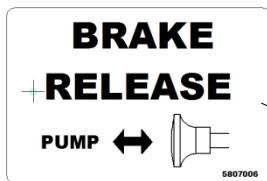

602047020018

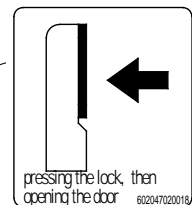

941200300007



602047020001

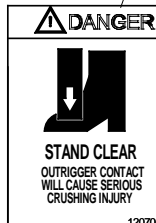
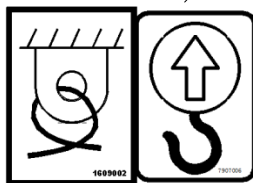
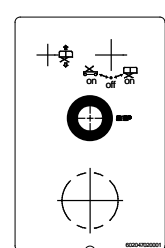

602047020005

941200300010

602047020025

941200100030



## General safety

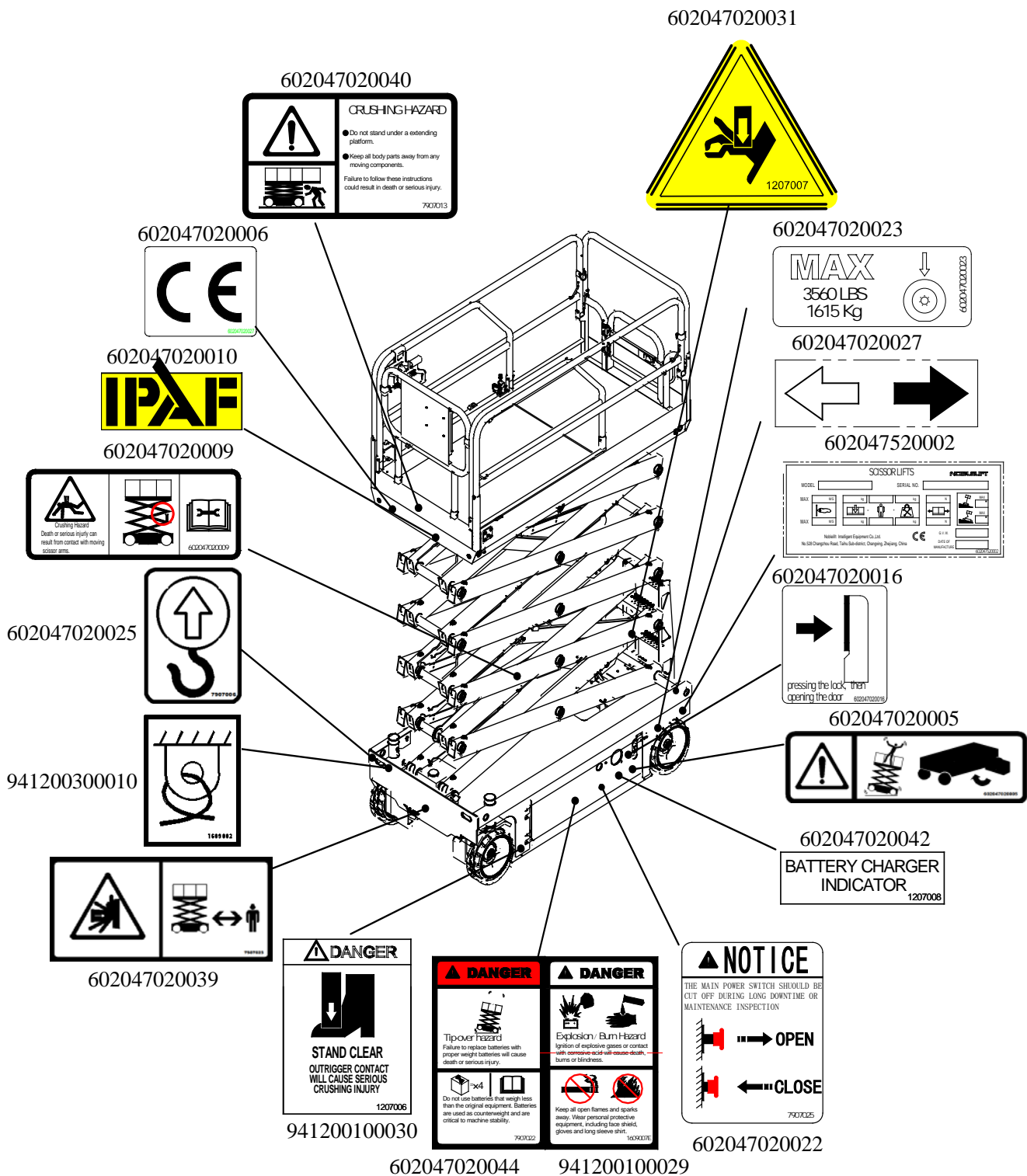

## Personal Safety

### Personal Fall Protection

Personal fall protection equipment (PFPE) is not required when operating this machine. If PFPE is required by job site or employer rules, the following shall apply:

All PFPE must comply with applicable governmental regulations and must be inspected and used in accordance with the manufacturer's instructions.

## Work Area Safety



### Electrocution Hazards

This machine is not electrically insulated and will not provide protection from contact with or proximity to electrical current.



Obey all local and governmental regulations regarding required clearance from electrical power lines. At a minimum, the required clearance contained in the chart below must be followed.

Line Voltage	Required Clearance
0 to 50KV	3.05 m
50 to 200KV	4.60 m
200 to 350KV	6.10 m
350 to 500KV	7.62 m
500 to 750KV	10.67 m
750 to 1000KV	13.72 m

Allow for platform movement, electrical line sway or sag, and beware of strong or gusty winds.



Keep away from the machine if it contacts energized power lines. Personnel on the ground or in the platform must not touch or operate the machine until energized power lines are shut off.

Do not operate the machine during lightning or storms.

Do not use the machine as a ground for welding.



### Tip-over Hazards

Occupants, equipment and materials shall not exceed the maximum platform capacity or the maximum platform capacity of the platform extension.

Model	Capacity
SC10H/SC10E	450Kg
SC12H/SC12E	320Kg
SC14H/SC14E	320Kg
SC16H/SC16E	200Kg
SC08HN/ SC08EN	380Kg
SC10HN/ SC10EN	230Kg

## Work Area Safety



- ◆ Do not raise the platform unless the machine is on a firm, level surface.
- ◆ Do not depend on the tilt alarm as a level indicator. The tilt alarm sounds on the chassis only when the machine is on a severe slope.



- ◆ If the tilt alarm sounds: Lower the platform. Move the machine to a firm, level surface. If the tilt alarm sounds when the platform is raised, use extreme caution to lower the platform.
- ◆ Do not drive over 0.8 km/h with the platform raised.

- ◆ **Outdoor Use:** Do not raise the platform when wind speeds may exceed 12.5 m/s. If wind speeds exceed 12.5 m/s when the platform is raised, lower the platform and do not continue to operate the machine.
- ◆ **Indoor Use:** When raising the platform, follow ratings for allowable side force and number of occupants on the next page.



Do not operate the machine in strong or gusty winds. Do not increase the surface area of the platform or the load. Increasing the area exposed to the wind will decrease machine stability.



Use extreme care and slow speeds while driving the machine in the stowed position across uneven terrain, debris, unstable or slippery surfaces and near holes and drop-offs.

- ◆ Do not drive the machine on or near uneven terrain, unstable surfaces or other hazardous conditions with the platform raised.
- ◆ Do not use the machine as a crane.
- ◆ Do not push the machine or other objects with the platform.
- ◆ Do not contact adjacent structures with the platform.
- ◆ Do not tie the platform to adjacent structures.
- ◆ Do not place loads outside the platform perimeter.
- ◆ Do not operate the machine with the chassis trays open.

## Work Area Safety



Do not push off or pull toward any object outside of the platform.

Model	Manual Force		Maximum occupants	
	Outdoor	Indoor	Outdoor	Indoor
<b>SC10H/SC10E</b>	200N	400N	1	2
<b>SC12H/SC12E</b>	200N	400N	1	2
<b>SC14H/SC14E</b>	-	400N	-	3
<b>SC16H/SC16E</b>	-	400N	-	2
<b>SC08HN/SC08EN</b>	200	400N	1	2
<b>SC10HN/SC10EN</b>	-	400N	-	2

- ◆ Do not alter or disable the limit switches.
- ◆ Do not alter or disable machine components that in any way affect safety and stability.
- ◆ Do not replace items critical to machine stability with items of different weight or specification.
- ◆ Do not use batteries that weigh less than the original equipment. Batteries are used as counterweight and are critical to machine stability. Each battery must reach the specified weight. For SC10H/ SC10E and SC12H/ SC12E machines, each battery must weigh 33kg. For SC14H / SC14E machines, each battery must weigh 35.5kg. For SC16H / SC16E machines, each battery must weigh 34kg. For SC08HN / SC08EN machines, each battery must weigh 28kg. For SC10HN / SC10EN machines, each battery must weigh 28kg.
- ◆ Do not modify or alter an aerial work platform without prior written permission from the manufacturer. Mounting attachments for holding tools or other materials onto the platform, toe boards or guard rail system can increase the weight in the platform and the surface area of the platform or the load.

## Work Area Safety



- ◆ Do not place or attach fixed or overhanging loads to any part of this machine.



- ◆ Do not place ladders or scaffolds in the platform or against any part of this machine.

- ◆ Do not transport tools and materials unless they are evenly distributed and can be safely handled by person(s) in the platform.
- ◆ Do not use the machine on a moving or mobile surface or vehicle. Be sure all tires are in good condition, castle nuts are properly tightened and cotter pins are properly installed.

### If equipped with outriggers

Do not set the machine up where it cannot be leveled using only the outriggers.

Do not adjust the outriggers while the platform is raised.

Do not drive while the outriggers are lowered.



### Crushing Hazard

Keep hands and limbs out of scissors.

Do not work under the platform or in the scissor links without the safety arm in place.

Use common sense and planning when operating the machine with the controller from the ground. Maintain safe distances between the operator, the machine and fixed objects.

## Work Area Safety



### Operation on Slopes Hazards

Do not drive the machine on a slope that exceeds the slope and side slope rating of the machine. Slope rating applies to machines in the stowed position.

Model	Maximum slope rating, stowed position	Maximum side slope rating, stowed position
SC10H/SC10E	25%	25%
SC12H/SC12E	25%	25%
SC14H/SC14E	25%	25%
SC16H/SC16E	25%	25%
SC08HN/SC08EN	25%	25%
SC10HN/SC10EN	25%	25%

**Note:** Slope rating is subject to ground conditions and adequate traction.



### Fall Hazards

The guard rail system provides fall protection. If occupant(s) of the platform are required to wear personal fall protection equipment (PFPE) due to job site or employer rules, PFPE and its use shall be in accordance with the PFPE manufacturer's instructions and applicable governmental requirements. Attach the lanyard to the anchor provided in the platform.



- ◆ Do not sit, stand or climb on the platform guard rails. Maintain a firm footing on the platform floor at all times.



- ◆ Do not climb down from the platform when raised.

- ◆ Keep the platform floor clear of debris.
- ◆ Do not enter or exit the platform unless the machine is in the stowed position.
- ◆ Attach the platform entry chain or close the entry gate before operating.
- ◆ Do not operate the machine unless the guard rails are properly installed and the entry is secured for operation.

## Work Area Safety



### Collision Hazards



- ◆ Be aware of limited sight distance and blind spots when driving or operating.
- ◆ Be aware of extended platform position when moving the machine.
- ◆ The machine must be on a level surface or secured before releasing the brakes.
- ◆ Operators must comply with employer, job site and governmental rules regarding use of personal protective equipment.



- ◆ Check the work area for overhead obstructions or other possible hazards.



- ◆ Be aware of crushing hazards when grasping the platform guard rail.

Observe and use color-coded direction arrows on the platform controls and the platform decal plate for drive and steer functions.



- ◆ Do not lower the platform unless the area below is clear of personnel and obstructions.



- ◆ Limit travel speed according to the condition of the ground surface, congestion, slope, location of personnel, and any other factors which may cause collision.

Do not operate a machine in the path of any crane or moving overhead machinery unless the controls of the crane have been locked out and or precautions have been taken to prevent any potential collision.

No stunt driving or horseplay while operating a machine.



## Work Area Safety



### **Bodily Injury Hazard**

Do not operate the machine with a hydraulic oil or air leak. An air leak or hydraulic leak can penetrate and/or burn skin.

Improper contact with components under any cover will cause serious injury. Only trained maintenance personnel should access compartments. Access by the operator is only advised when performing a pre-operation inspection. All compartments must remain closed and secured during operation.



### **Explosion and Fire Hazards**

Do not operate the machine or charge the battery in hazardous locations or locations where potentially flammable or explosive gases or particles may be present.



### **Damaged Machine Hazards**

Do not use a damaged or malfunctioning machine.

Conduct a thorough pre-operation inspection of the machine and test all functions before each work shift. Immediately tag and remove from service a damaged or malfunctioning machine.

Be sure all maintenance has been performed as specified in this manual and the appropriate Noblelift service manual.

Be sure all decals are in place and legible.

Be sure the operator's, safety and responsibilities manuals are complete, legible and in the storage container located on the machine.



### **Component Damage Hazards**

Do not use any battery charger greater than 24V to charge the batteries. Do not use the machine as a ground for welding.

## Work Area Safety



### Battery Safety

#### Burn Hazards



- ◆ Batteries contain acid. Always wear protective clothing and eye wear when working with batteries.
- ◆ Avoid spilling or contacting battery acid. Neutralize battery acid spills with baking soda and water.
- ◆ Do not expose the batteries or the charger to water or rain during charging.

#### Explosion Hazards



- ◆ Keep sparks, flames and lighted tobacco away from batteries.
- ◆ Batteries emit explosive gas.
- ◆ The battery tray should remain open during the entire charging cycle. Do not contact the battery terminals or the cable clamps with tools that may cause sparks.

#### Component Damage Hazard

- ◆ Do not use any battery charger greater than 24V to charge the batteries.

#### Electrocution/Burn Hazards



- ◆ Connect the battery charger to a grounded, AC 3-wire electrical outlet only.
- ◆ Inspect daily for damaged cords, cables and wires. Replace damaged items before operating.
- ◆ Avoid electrical shock from contact with battery terminals. Remove all rings, watches and other jewelry.

#### Tip-over Hazard

- ◆ Do not use batteries that weigh less than the original equipment. Batteries are used as counterweight and are critical to machine stability. Each battery must reach the specified weight. For SC10H/ SC10E and SC12H/ SC12E machines, each battery must weigh 33kg. For SC14H/ SC14E machines, each battery must weigh 35.5kg. For SC16H/ SC16E machines, each battery must weigh 34kg. For SC08HN/ SC08EN machines, each battery must weigh 28kg. For SC10HN/ SC10EN machines, each battery must weigh 28kg.

## Work Area Safety

### Lifting Hazard

- ◆ Use the appropriate number of people and proper lifting techniques when lifting batteries.

### Lockout After Each Use

- 1 Select a safe parking location—firm level surface, clear of obstruction and traffic.
- 2 Lower the platform.
- 3 Turn the key switch to the off position and remove the key to secure from unauthorized use.
- 4 Charge the batteries.

## Legend

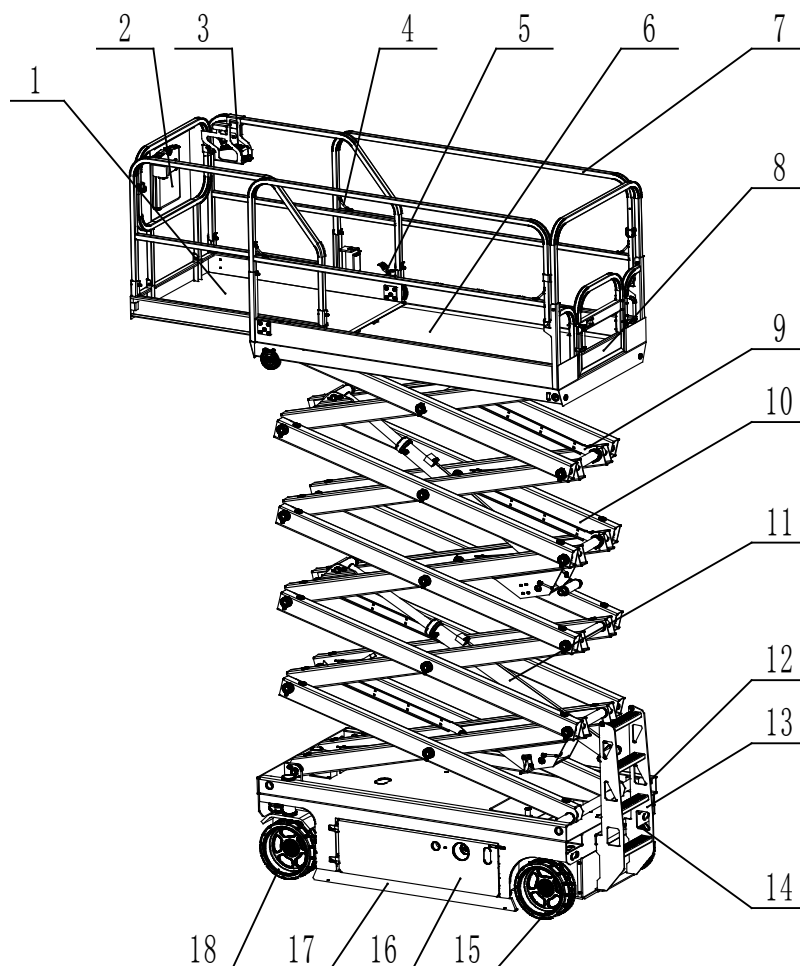

- |   |                                  |    |   |
|---|----------------------------------|----|---|
| 1 | Extension platform               | 10 | Scissors arm  |
| 2 | Manual box                       | 11 | Lifting cylinder  |
| 3 | Platform controller              | 12 | Ground controller (on the opposite side of the machine) |
| 4 | Fixed lanyard                    | 13 | Entrance ladder   |
| 5 | Platform extension release pedal | 14 | Brake release pump                                      |
| 6 | Fixed platform                   | 15 | Non steering wheel                                      |
| 7 | Platform barrier                 | 16 | Charger   |
| 8 | Platform entrance door           | 17 | Pothole protection device                               |
| 9 | Safety arm                       | 18 | Steering wheel  |

## Controls

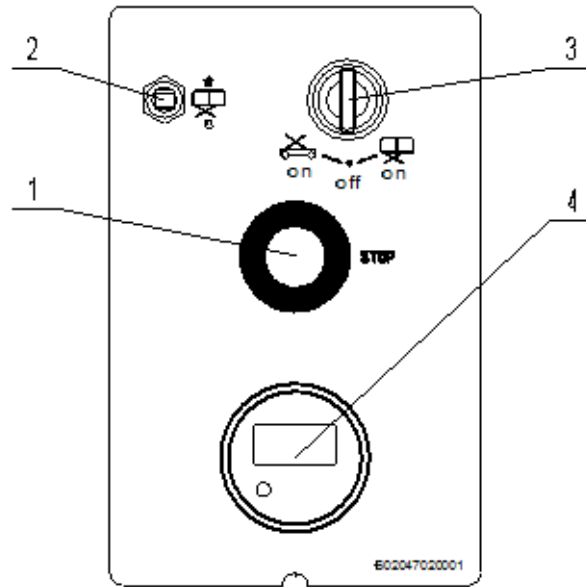

### Ground control panel

#### 1 Chassis emergency stop switch

Pull the switch out of the power supply, power on; press the switch, power off. The red mushroom shaped emergency stop switch is in the open position, the key selection switch is grounded, and the operation power is supplied to the ground operation station key switch. In addition, the power supply of the functional control unit can be closed by using the switch in an emergency situation.

#### 2 Platform to enhance or reduce switch

The three gear instantaneous contact lifting control switch can be used for raising and lowering the working platform from the chassis control platform. In through the chassis control unit operation work platform, lifting or lowering the switch to on position, and hold it in this position, lifting work platform, to maintain the downward position and the elevated working platform can be lowered. In the middle of release, can stop all activities.

#### 3 Key selector switch

The key selector switch on the ground console is used to switch on the power supply for the console to be used. When the switch is rotated to the position of the chassis, the power is switched on to the control unit of the ground console(1).

When the switch is rotated to the position of the working platform(3), the power is switched on to the control unit of the working platform.

If the device is to be stationed in the car for the night, the switch should be set at the close position(2).

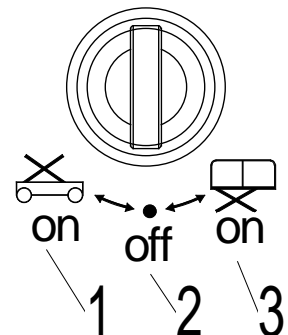

#### 4、Timer

Timer can display the current working time.

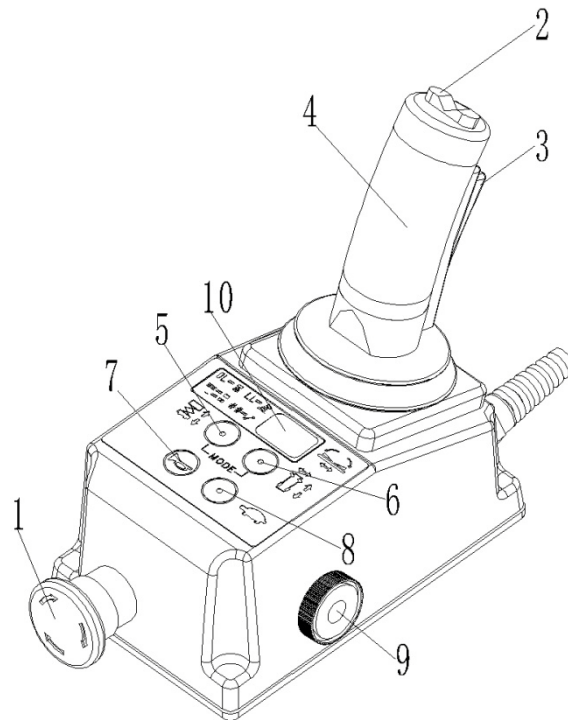

### Platform control panel

#### 1 Emergency stop button

Push the red “emergency stop button” to the inside(off) and stop all the functions.Turn the red “emergency stop” button(on),and operate the machine.

#### 2 Steering switch

The steering switch is a switch which is located on the top of control handle and is operate by the thumb.Press the switch on the right to drive the wheel to the right.Press the switch on the left to drive the wheel to the left.

#### 3 Trigger switch

This switch is located on the front side of the joystick controller.The trigger switch is used as an opening device and must be pressed before running,steering,and lifting functions.After the release,the function being operated will stop.

*Note:After pressing the trigger switch,the operator has (5) seconds to start the operation function,5 seconds after the trigger switch must be released,and then press the switch again to operate the joystick function.The operation speed of all functions is proportional to the distance from the center of the control lever controller.*

*Note: If the device is equipped with a foot switch, it is necessary to step down and the red trigger switch is located on the controller.When the pedal switch is loosened,the power supply of the working platform control is disconnected.*

## Controls

### 4 joystick controller

Joystick controller controls three functions: promotion, driving, steering. After selecting the required function, the handle is operated in a series of function to achieve the function.

### 5 Lift button

After pressing this button, the machine is in a state of lifting.

### 6 Travel/Steering button

After pressing this button, the machine is in a state of travel and steering.

### 7 Horn button

The horn button is pressed, the horn will be ringing. Release the horn button, the horn will not.

### 8 Turtle button(Driver speed button)

When the position is retracted, the drive controller can operate under two different driving speed modes. When the drive speed button light is on, the slow drive speed mode is in the active state. When the drive speed button lamp goes out, the fast driving speed mode is in the active state. Press the drive speed button to select the desired drive speed.

**Note:** When the platform is raised, the driving speed button lamp is always on, so as to indicate the increase of the driving speed.

### 9 Alarm/Buzzer

The alarm can be issued in a variety of situation when the device is issued a warning sound, or the system is ready to drop the sound (such as the system is ready to prompt sound or if the machine is inclined to alert the start).

### 10 Display screen

The display screen can display the discharge indicator of the battery, which can display the machine overload warning and the incitation warning and the system limit indication lamp.

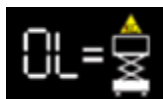

-----Indicates that the platform has been overloaded. Working platform overload will be heard when the alarm sound.

**Note:** If the overload indicator is lit, all functions are disabled from the working platform and the ground control. To reduce the weight of the working platform so that it does not exceed the load capacity on the load capacity of the designated work load.

## Controls

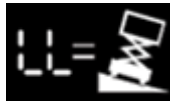

-----Indicates that the chassis is located in or over an inclined notch setting. So the alarm will be heard.

*Note: When lifting the working platform, if the tilt indicator warning lights or alarm start, should be reduced to the working platform, and moving to a flat, solid level of ground.*



-----Display battery power

Platform display	Quantity of electricity	Description
	90-100	Electricity is full
	70	Residual quantity of electricity
	50	Residual quantity of electricity
	30	Residual quantity of electricity
	20	Must charge
	10	Power is very low, the machine into the low speed

Figure 3-3 battery power

### ⚠ CAUTION

*Do not reduce the platform before the full extension of the extension platform.*

*If platform is lifted out of the storage position and is in a state of high speed, please do not do any other operation.*



## Inspections



### Do Not Operate Unless:

You learn and practice the principles of safe machine operation contained in this operator's manual

- 1 Avoid hazardous situations.
- 2 Always perform a pre-operation inspection.

Know and understand the pre-operation inspection before going on to the next section.

- 3 Always perform function tests prior to use.
- 4 Inspect the workplace.
- 5 Only use the machine as it was intended.

### Pre-operation Inspection Fundamentals

It is the responsibility of the operator to perform a pre-operation inspection and routine maintenance.

The pre-operation inspection is a visual inspection performed by the operator prior to each work shift. The inspection is designed to discover if anything is apparently wrong with a machine before the operator performs the function tests.

The pre-operation inspection also serves to determine if routine maintenance procedures are required. Only routine maintenance items specified in this manual may be performed by the operator.

Refer to the list on the next page and check each of the items.

If damage or any unauthorized variation from factory delivered condition is discovered, the machine must be tagged and removed from service.

Repairs to the machine may only be made by a qualified service technician, according to the manufacturer's specifications. After repairs are completed, the operator must perform a pre-operation inspection again before going on to the function tests.

Scheduled maintenance inspections shall be performed by qualified service technicians, according to the manufacturer's specifications and the requirements listed in the responsibilities manual.

## Inspections

### Pre-operation Inspection

- Be sure that the operator's, safety and responsibilities manuals are complete, legible and in the storage container located in the platform.
- Be sure that all decals are legible and in place. See Inspections section.
- Check for hydraulic oil leaks and proper oil level. Add oil if needed. See Maintenance section.
- Check for battery fluid leaks and proper fluid level. Add distilled water if needed. See Maintenance section.

Check the following components or areas for damage, improperly installed or missing parts and unauthorized modifications:

- |  |   |
|--|---|
| <input type="checkbox"/> Electrical components, wiring and electrical cables | <input type="checkbox"/> Hydraulic hoses, fittings, cylinders and manifolds |
| <input type="checkbox"/> Drive motors  | <input type="checkbox"/> Scissor pins and retaining fasteners               |
| <input type="checkbox"/> Wear pads   | <input type="checkbox"/> Platform control joystick                          |
| <input type="checkbox"/> Tires and wheels                                    | <input type="checkbox"/> Battery pack and connections                       |
| <input type="checkbox"/> Limit switches, alarms and horn                     | <input type="checkbox"/> Ground strap                                       |
| <input type="checkbox"/> Alarms and beacons (if equipped)                    | <input type="checkbox"/> Platform entry chain or gate                       |
| <input type="checkbox"/> Nuts, bolts and other fasteners                     | <input type="checkbox"/> Pothole guards                                     |
| <input type="checkbox"/> Brake release components                            | <input type="checkbox"/> Lanyard anchorage points                           |
| <input type="checkbox"/> Safety arm  | <input type="checkbox"/> Outrigger housing and footpads (if equipped)       |
| <input type="checkbox"/> Platform extension                                  | <input type="checkbox"/> Platform overload components                       |

Check entire machine for:

- |   |   |
|---|---|
| <input type="checkbox"/> Cracks in welds or structural components | <input type="checkbox"/> Dents or damage to machine |
| <input type="checkbox"/> Excessive rust, corrosion or oxidation   |   |
- Be sure that all structural and other critical components are present and all associated fasteners and pins are in place and properly tightened.
  - Be sure side rails are installed and bolts are fastened.
  - Be sure that the chassis trays are closed and latched and the batteries are properly connected.

**Note:** If the platform must be raised to inspect the machine, make sure the safety arm is in place. See Operating Instructions section.

## Inspections



### **Do Not Operate Unless:**

You learn and practice the principles of safe machine operation contained in this operator's manual.

- 1 Avoid hazardous situations.
- 2 Always perform a pre-operation inspection.
- 3 Always perform function tests prior to use.

Know and understand the function tests before going on to the next section.

- 4 Inspect the workplace.
- 5 Only use the machine as it was intended.

### **Function Test Fundamentals**

The function tests are designed to discover any malfunctions before the machine is put into service. The operator must follow the step-by-step instructions to test all machine functions.

A malfunctioning machine must never be used. If malfunctions are discovered, the machine must be tagged and removed from service. Repairs to the machine may only be made by a qualified service technician, according to the manufacturer's specifications.

After repairs are completed, the operator must perform a pre-operation inspection and function tests again before putting the machine into service.

## Inspections

### At the Ground Controls

- 1 Select a test area that is firm, level and free of obstruction.
- 2 Be sure the batteries are connected.
- 3 Pull out the platform and ground red Emergency Stop button to the on position.
- 4 Turn the key switch to ground control.
- 5 Observe the diagnostic LED readout on the platform controls. ●Result: The LED should look like the picture below.



### Test Emergency Stop

- 7 Push in the ground red Emergency Stop button to the off position. ●Result: No functions should operate.
- 8 Pull out the red Emergency Stop button to the on position.

### Test the Up/Down Functions

This machine uses both flashing lights and audible alarms.

Descent alarm: Lights flash and alarm sounds at 60 flashes/beeps per minute.

Descent delay alarm: Lights flash and alarm sounds at 180 flashes/beeps per minute.

Pothole guards not deployed: Lights flash and alarm sounds at 180 flashes/beeps per minute.

Machine not level: Lights flash and alarm sounds at 180 flashes/beeps per minute.

Horn: continuous flash and constant tone. An optional automotive-style horn is also available

- 9 Do not press the lift function enable button.
- 10 Press the platform up or platform down button. ●Result: The lift function should not operate.
- 11 Do not press the platform up or platform down buttons.
- 12 Press the lift function enable button. ●Result: The lift function should not operate.
- 13 Press and hold the lift function enable button, and press the platform up button. ●Result: The platform should raise.
- 14 Press and hold the lift function enable button, and press the platform down button. ●Result: The platform should lower. The descent alarm should flash and sound while the platform is lowering.

When lowering the platform, the platform should stop when it is approximately 2.1 m from the ground. The descent delay lights will flash and the alarm will sound. Be sure the area below the platform is clear of personnel and obstructions before continuing. To continue lowering, release the control handle, and then move the control handle again.

## Inspections

### Test Emergency Lowering

- 15 Activate the up function by pressing the lift enable button and platform up button, and raise the platform approximately 60 cm.
- 16 Push out the emergency descent control button.

### At the Platform Controls

#### Test Emergency Stop

- 17 Push in the platform red Emergency Stop button to the off position. ●Result: No functions should operate.

#### Test the Horn

- 18 Pull out the red Emergency Stop button to the on position.
- 19 Press the horn button. ●Result: The horn should sound.

#### Test the Function Enable Switch and the Up/Down Functions

- 20 Do not hold the function enable switch on the control handle.
- 21 Slowly move the control handle in the direction indicated by the blue arrow, then in the direction indicated by the yellow arrow.  
●Result: No functions should operate.
- 22 Press the lift function button.
- 23 Wait seven seconds for the lift function to time out.
- 24 Slowly move the control handle in the direction indicated by the blue arrow, then in the direction indicated by the yellow arrow.  
●Result: The lift function should not operate.
- 25 Press the lift function button.
- 26 Press and hold the function enable switch on the control handle. Slowly move the control handle in the direction indicated by the blue arrow.  
Machines equipped with foot switch: Press and hold the foot switch and press and hold the function enable switch on the control handle at the same time.  
●Result: The platform should raise. The pothole guards should deploy.
- 27 Release the control handle.  
●Result: The platform should stop raising.
- 28 Press and hold the function enable switch on the control handle. Slowly move the control handle in the direction indicated by the yellow arrow.  
●Result: The platform should lower.

## Inspections

### Test the Drive Function Button

29 Press the drive function button

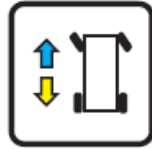

30 Wait seven seconds for the drive function to time out.

31 Slowly move the control handle in the direction indicated by the blue arrow, then in the direction indicated by the yellow arrow.

- Result: No functions should operate.

### Test the Steering

**Note:** When performing the steer and drive function tests, stand in the platform facing the steer end of the machine.

32 Press the drive function button.

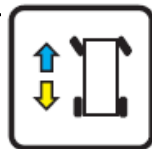

33 Press and hold the function enable switch on the control handle.

34 Press the thumb rocker switch on top of the control handle in the direction indicated by the blue triangle on the control panel.

- Result: The steer wheels should turn in the direction indicated by the blue triangle.

35 Press the thumb rocker switch on top of the control handle in the direction indicated by the yellow triangle, on the control panel.

- Result: The steer wheels should turn in the direction indicated by the yellow triangle.

### Test Drive and Braking

36 Press the drive function button.

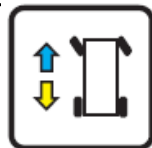

37 Press and hold the function enable switch on the control handle.

Machines equipped with foot switch: Press and hold the foot switch and press and hold the function enable switch on the control handle at the same time.

38 Slowly move the control handle in the direction indicated by the blue arrow on the control panel until the machine begins to move, then return the control handle to the center position.

- Result: The machine should move in the direction that the blue arrow points on the control panel, then come to an abrupt stop when the control handle is returned to the center position.

39 Slowly move the control handle in the direction indicated by the yellow arrow on the control panel until the machine begins to move, then return the control handle to the center position.

## Inspections

- Result: The machine should move in the direction that the yellow arrow points on the control panel, then come to an abrupt stop when the control handle is returned to the center position.

**Note:** The brakes must be able to hold the machine on any slope it is able to climb.

### Test the Tilt Sensor Operation

**Note:** Perform this test from the ground with the platform controller. Do not stand in the platform.

- 40 Fully lower the platform.
- 41 Place a 2x4 or similar piece of wood under both wheels on one side and drive the machine up onto them.
- 42 Raise the platform approximately 2.1 m from the ground.
  - Result: The platform should stop. The tilt alarm should sound and the lights should flash.
- 43 Press the drive function button.

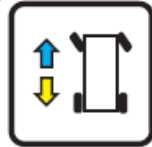

- 44 Press and hold the function enable switch on the control handle.
- 45 Move the control handle in the direction indicated by the blue arrow, then move the control handle in the direction indicated by the yellow arrow.
  - Result: The drive function should not work in either direction.
- 46 Lower the platform and remove both pieces of wood.

### Test Elevated Drive Speed

- 47 Raise the platform approximately 1.2 m from the ground.
- 48 Press the drive function button.

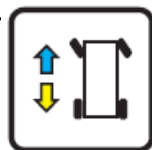

- 49 Press and hold the function enable switch on the control handle. Slowly move the control handle to full drive position.
  - Result: The maximum achievable drive speed with the platform raised should not exceed 22 cm/s.

If the drive speed with the platform raised exceeds 22 cm/s, immediately tag and remove the machine from service.

## Inspections

### Test the Pothole Guards

Note: The pothole guards should automatically deploy when the platform is raised. The pothole guards activate limit switches that allow the machine to continue to function. If the pothole guards do not deploy, an alarm sounds and the machine will not drive or steer.

50 Raise the platform.

- Result: When the platform is raised 1.2 m from the ground, the pothole guards should deploy.

51 Press on the pothole guards on one side, and then the other.

52 Lower the platform

- Result: The pothole guards should return to the stowed position.

53 Place a 2x4 or similar piece of wood under a pothole guard.

54 Raise the platform.

- Result: Before the platform is raised 2.1 m from the ground, the lights should flash and an alarm should sound.

55 Press the drive function button.



56 Press and hold the function enable switch on the control handle.

57 Slowly move the control handle in the direction indicated by the blue arrow, then in the direction indicated by the yellow arrow.

- Result: The machine should not move forward or backward.

58 Press the drive function button

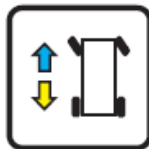

59 Press and hold the function enable switch on the control handle.

60 Press the thumb rocker switch on top of the control handle in the direction indicated by the blue and yellow triangles on the control panel.

- Result: The steer wheels should not turn left or right.

61 Lower the platform.

62 Remove the 2x4 or similar piece of wood.



## Inspections



### Do Not Operate Unless:

- You learn and practice the principles of safe machine operation contained in this operator's manual.
  - 1 Avoid hazardous situations.
  - 2 Always perform a pre-operation inspection.
  - 3 Always perform function tests prior to use.
  - 4 Inspect the workplace.

Know and understand the workplace inspection before going on to the next section.
  - 5 Only use the machine as it was intended.

### Workplace Inspection Fundamentals

The workplace inspection helps the operator determine if the workplace is suitable for safe machine operation. It should be performed by the operator prior to moving the machine to the workplace.

It is the operator's responsibility to read and remember the workplace hazards, then watch for and avoid them while moving, setting up and operating the machine.

### Workplace Inspection Checklist

Be aware of and avoid the following hazardous situations:

- 1 drop-offs or holes
- 2 bumps, floor obstructions or debris
- 3 sloped surfaces
- 4 unstable or slippery surfaces
- 5 overhead obstructions and high voltage conductors
- 6 hazardous locations
- 7 inadequate surface support to withstand all load forces imposed by the machine
- 8 wind and weather conditions
- 9 the presence of unauthorized personnel
- 10 other possible unsafe conditions

## Inspections

SC10H\SC12H \SC14H\SC10E\SC12E\SC14E\SC08HN\SC10HN\SC08EN\SC10EN

Use the pictures on the next page to verify that all decals are legible and in place.

Below is a numerical list with quantities and descriptions. POONHBBGH

Part No.	Decal number	Decal Description	Qty
1	601547020001	Product model label(be confined only to SC10H)	2
	602047020002	Product model label(be confined only to SC12H)	
	602547020001	Product model label(be confined only to SC14H)	
	606547020001	Product model label(be confined only to SC16H)	
	604047020001	Product model label(be confined only to SC10E)	
	604547020001	Product model label(be confined only to SC12E)	
	605047020001	Product model label(be confined only to SC14E)	
	607047020001	Product model label(be confined only to SC16E)	
	600547020001	Product model label(be confined only to SC08HN)	
	601047020001	Product model label(be confined only to SC10HN)	
	603047020001	Product model label(be confined only to SC08EN)	
	603547020001	Product model label(be confined only to SC10EN)	
2	941200300006	Safety belt label	4
3	601547020002	Platform warning label 2(be confined only to SC10H/SC10E)	1
	602047020008	Platform warning label 2(be confined only to SC12H/SC12E)	
	602547020002	Platform warning label 2(be confined only to SC14H/SC14E)	
	606547020002	Platform warning label 2(be confined only to SC16H/SC16E)	
	600547020002	Platform warning label 2(be confined only to SC08HN/SC08EN)	
	601047020002	Platform warning label 2(be confined only to SC10HN/SC10EN)	
4	602047020045	Brake release button warning label	1
5	602047020046	Brake release label	1
6	941200300007	Forklift truck transportation label	1
7	602047020025	Lifting sign	4
8	941200300010	Traction mark	4
9	941200100030	Leg warning label	2
10	602047020005	Chassis operation warning label	2
11	602047020016	Chassis lock tips	1
	602047020018	Chassis lock tips 2	
12	602047020001	Chassis operation label	1
13	602047020024	Manual drop device	1

## Inspections

14	602047020031	Anti pinch hand warning label	1
15	602047020028	Noblelift sign(1)	2
16	602047020014	Operation warning label	1
17	602047020015	Operation warning label 2	1
18	601547020004	Platform warning label(be confined only to SC10H/SC10E)	1
	602047020019	Platform warning label(be confined only to SC12H/SC12E)	
	602547020004	Platform warning label(be confined only to SC14H/SC14E)	
	606547020004	Platform warning label(be confined only to SC16H/SC16E)	
	600547020004	Platform warning label(be confined only to SC08HN/SC08EN)	
	601047020004	Platform warning label(be confined only to SC10HN/SC10EN)	
19	602047020040	Pressure warning label (1)	1
20	602047020006	CE label	1
21	602047020010	IPAF label	1
22	602047020009	Scissors warning label	1
23	602047020039	Anti collision label	1
24	941200100029	Battery maintenance warning label	1
25	602047020044	Battery replacement label	1
26	602047020022	Emergency stop switch	1
27	602047020042	Charging indication label	1
28	602047520002	Nameplate	1
29	602047020027	Forward backward sign	2
30	602047020023	Maximum load bearing mark	4

## Inspections

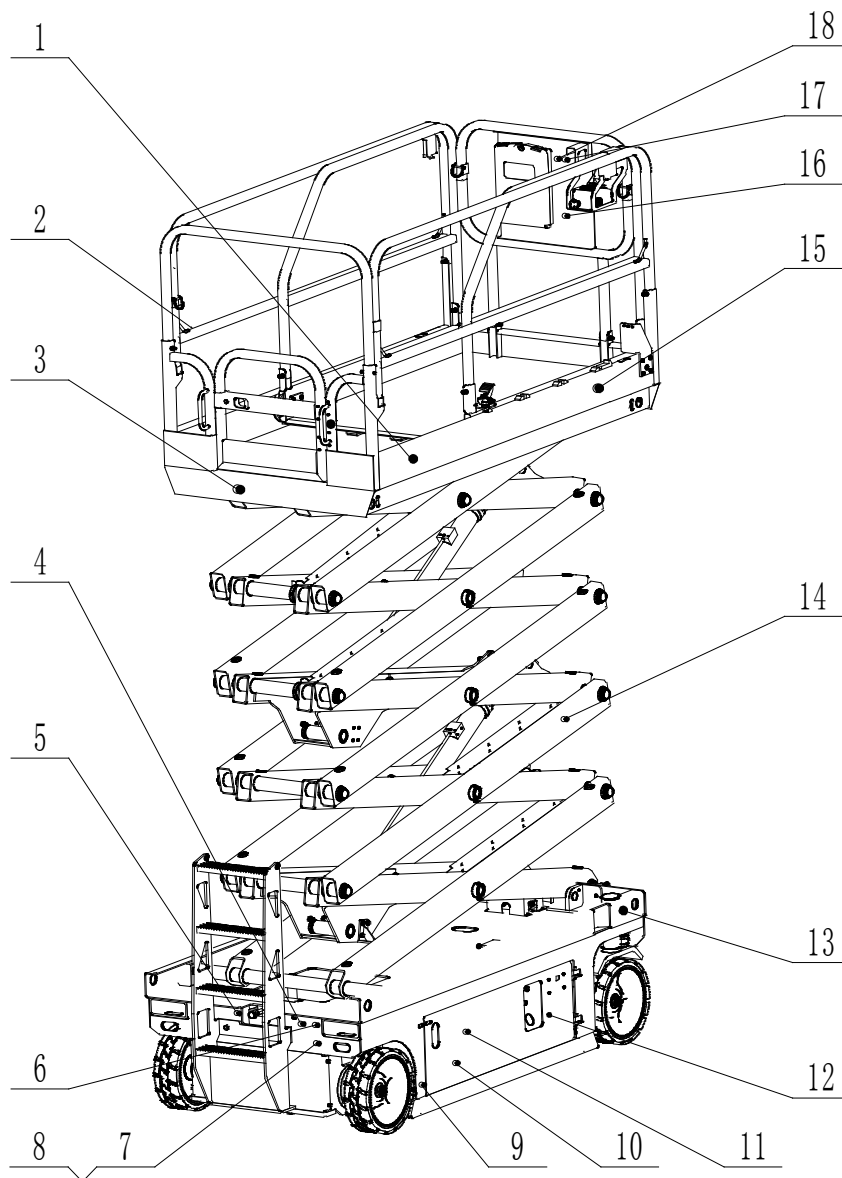

## Inspections

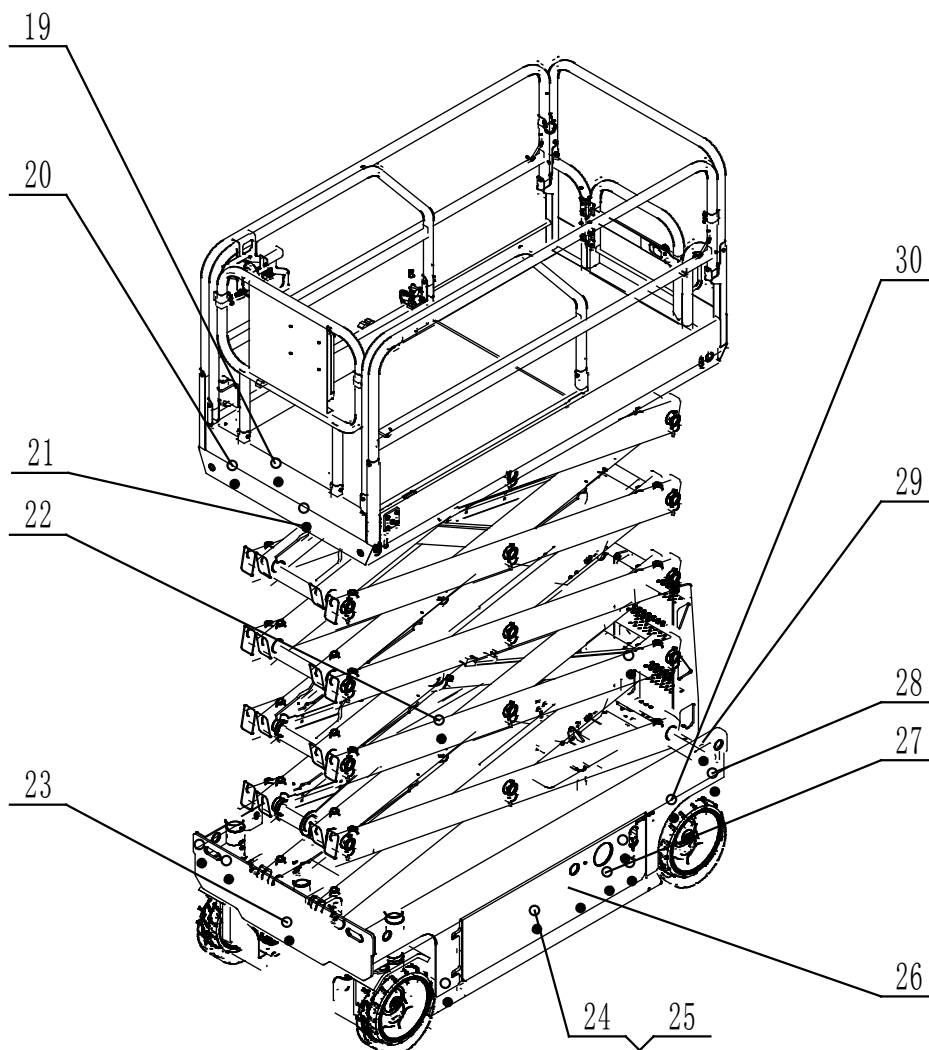

## Specifications

### SC10H

Save working load	450kg
Extended platform save working load	113kg
Maximum number of working people (indoor)	2
Maximum number of working people (outdoor)	1
Maximum working height(A)	10m
Maximum platform height(B)	8m
Vehicle length(C)	2.48m
Vehicle width(D)	1.15m
Vehicle height (fence not folded) (E)	2.32m
Vehicle height (fence folding)	1.78m
Platform dimension(length×width F)	2.27x1.12m
Platform extension dimension(G)	0.9m
Minimum ground clearance (collapsed state)	0.10m
Minimum ground clearance (Lifting state)	0.019m
Wheelbase	1.87m
Minimum radius of rotation	2.2m
Lifting/Driving motor	24V/4.5kw
Machine travel speed (collapsed state)	3.2 km/h
Machine travel speed (Lifting state)	0.8 km/h
Lifting/Lower speed	27/36s
Battery	4 x 6V/232Ah
Charger	24V/30A
Max climb capability	25%
Maximum allowable working angel	2°/3°
Wheel	Φ381x127mm
Vehicle weight	2655kg
Maximum working pressure	240bar
Airborne noise emissions	
Sound pressure level at ground workstation	<70dBA
Sound pressure level atplatform workstation	<70dBA
Ground bearing information	
Maximum wheel load	1050kg
Local tire pressure	10.3kg/cm <sup>2</sup> 1012.8kPa
Occupation pressure	922kg/m <sup>2</sup> 9.04kPa

## Specifications

### SC12H

Save working load	320kg
Extended platform Save working load	113kg
Maximum number of working people (indoor)	2
Maximum number of working people (outdoor)	1
Maximum working height(A)	12m
Maximum platform height(B)	10m
Vehicle length(C)	2.48m
Vehicle width(D)	1.15m
Vehicle height (fence not folded) (E)	2.44m
Vehicle height (fence folding)	1.92m
Platform dimension(length×width F)	2.27x1.12m
Platform extension dimension(G)	0.9m
Minimum ground clearance (collapsed state)	0.10m
Minimum ground clearance (Lifting state)	0.019m
Wheelbase	1.87m
Minimum radius of rotation	2.2m
Lifting/Driving motor	24V/4.5kw
Machine travel speed (collapsed state)	3.2 km/h
Machine travel speed (Lifting state)	0.8 km/h
Lifting/Lower speed	48/48s
Battery	4 x 6V/232Ah
Charger	24V/30A
Max climb capability	25%
Maximum allowable working angel	2°/3°
Wheel	Φ381x127mm
Vehicle weight	2990kg
Maximum working pressure	240bar
Airborne noise emissions	
Sound pressure level atground workstation	<70dBA
Sound pressure level atplatform workstation	<70dBA
Ground bearing information	
Maximum wheel load	1050kg
Local tire pressure	10.3kg/cm <sup>2</sup> 1012.8kPa
Occupation pressure	964kg/m <sup>2</sup> 9.45kPa

## Specifications

### SC14H

Save working load	320kg
Extended platform Save working load	113kg
Maximum number of working people (indoor)	3
Maximum number of working people (outdoor)	/
Maximum working height(A)	14m
Maximum platform height(B)	12m
Vehicle length(C)	2.48m
Vehicle width(D)	1.15m
Vehicle height (fence not folded) (E)	2.58m
Vehicle height (fence folding)	2.04m
Platform dimension(length×width F)	2.27x1.12m
Platform extension dimension(G)	0.9m
Minimum ground clearance (collapsed state)	0.10m
Minimum ground clearance (Lifting state)	0.019m
Wheelbase	1.87m
Minimum radius of rotation	2.2m
Lifting/Driving motor	24V/4.5kw
Machine travel speed (collapsed state)	3.2 km/h
Machine travel speed (Lifting state)	0.8 km/h
Lifting/Lower speed	80/60s
Battery	4 x 6V/280Ah
Charger	24V/30A
Max climb capability	25%
Maximum allowable working angel	1.5°/3°
Wheel	Φ381x127mm
Vehicle weight	2925kg
Maximum working pressure	240bar
Airborne noise emissions	
Sound pressure level atground workstation	<70dBA
Sound pressure level at platform workstation	<70dBA
Ground bearing information	
Maximum wheel load	1160kg
Local tire pressure	11.4kg/cm <sup>2</sup> 1118.9kPa
Occupation pressure	1115kg/m <sup>2</sup> 10.9kPa



## Specifications

### SC16H

Save working load	200kg
Extended platform Save working load	113kg
Maximum number of working people (indoor)	2
Maximum number of working people (outdoor)	/
Maximum working height(A)	15.7m
Maximum platform height(B)	13.7m
Vehicle length(C)	2.48m
Vehicle width(D)	1.15m
Vehicle height (fence not folded) (E)	2.58m
Vehicle height (fence folding)	2.17m
Platform dimension(length×width F)	2.64x1.02m
Platform extension dimension(G)	0.9m
Minimum ground clearance (collapsed state)	0.10m
Minimum ground clearance (Lifting state)	0.019m
Wheelbase	2.22m
Minimum radius of rotation	2.5m
Lifting/Driving motor	24V/4.5kw
Machine travel speed (collapsed state)	3.2km/h
Machine travel speed (Lifting state)	0.8 km/h
Lifting/Lower speed	70/52s
Battery	4 x 12V/310Ah
Charger	24V/30A
Max climb capability	25%
Maximum allowable working angel	1.5°/3°
Wheel	Φ381x127mm
Vehicle weight	3300kg
Maximum working pressure	240bar
<b>Airborne noise emissions</b>	
Sound pressure level atground workstation	<70dBA
Sound pressure level atplatform workstation	<70dBA
<b>Ground bearing information</b>	
Maximum wheel load	1160kg
Local tire pressure	11.4kg/cm <sup>2</sup>
	1118.9kPa
Occupation pressure	1004kg/m <sup>2</sup>
	9.8kPa

## Specifications

### SC10E

Save working load	450kg
Extended platform save working load	113kg
Maximum number of working people (indoor)	2
Maximum number of working people (outdoor)	1
Maximum working height(A)	10m
Maximum platform height(B)	8m
Vehicle length(C)	2.48m
Vehicle width(D)	1.15m
Vehicle height (fence not folded) (E)	2.32m
Vehicle height (fence folding)	1.78m
Platform dimension(length×width F)	2.27x1.12m
Platform extension dimension(G)	0.9m
Minimum ground clearance (collapsed state)	0.10m
Minimum ground clearance (Lifting state)	0.019m
Wheelbase	1.87m
Minimum radius of rotation (in/out)	2.2m
Lifting motor	24V/4.5kw
Driving motor	24V/1.5kw
Machine travel speed (collapsed state)	4.0 km/h
Machine travel speed (Lifting state)	0.8 km/h
Lifting/Lower speed	27/36s
Battery	4 x 6V/232Ah
Charger	24V/30A
Max climb capability	25%
Maximum allowable working angel	2°/3°
Wheel	Φ381x127mm
Vehicle weight	2655kg
Maximum working pressure	240bar
Airborne noise emissions	
Sound pressure level atground workstation	<70dBA
Sound pressure level atplatform workstation	<70dBA
Ground bearing information	
Maximum wheel load	1050kg
Local tire pressure	10.3kg/cm <sup>2</sup> 1012.8kPa
Occupation pressure	922kg/m <sup>2</sup> 9.04kPa

## Specifications

### SC12E

Save working load	320kg
Extended platform Save working load	113kg
Maximum number of working people (indoor)	2
Maximum number of working people (outdoor)	1
Maximum working height(A)	12m
Maximum platform height(B)	10m
Vehicle length(C)	2.48m
Vehicle width(D)	1.15m
Vehicle height (fence not folded) (E)	2.44m
Vehicle height (fence folding)	1.92m
Platform dimension(length×width F)	2.27x1.12m
Platform extension dimension(G)	0.9m
Minimum ground clearance (collapsed state)	0.10m
Minimum ground clearance (Lifting state)	0.019m
Wheelbase	1.87m
Minimum radius of rotation	2.2m
Lifting motor	24V/4.5kw
Driving motor	24V/1.5kw
Machine travel speed (collapsed state)	4.0 km/h
Machine travel speed (Lifting state)	0.8 km/h
Lifting/Lower speed	48/48s
Battery	4 x 6V/232Ah
Charger	24V/30A
Max climb capability	25%
Maximum allowable working angel	2°/3°
Wheel	Φ381x127mm
Vehicle weight	2990kg
Maximum working pressure	240bar
Airborne noise emissions	
Sound pressure level atground workstation	<70dBA
Sound pressure level atplatform workstation	<70dBA
Ground bearing information	
Maximum wheel load	1050kg
Local tire pressure	10.3kg/cm <sup>2</sup> 1012.8kPa
Occupation pressure	964kg/m <sup>2</sup> 9.45kPa

## Specifications

### SC14E

Save working load	320kg
Extended platform Save working load	113kg
Maximum number of working people (indoor)	3
Maximum number of working people (outdoor)	/
Maximum working height(A)	14m
Maximum platform height(B)	12m
Vehicle length(C)	2.48m
Vehicle width(D)	1.15m
Vehicle height (fence not folded) (E)	2.58m
Vehicle height (fence folding)	2.04m
Platform dimension(length×width F)	2.27x1.12m
Platform extension dimension(G)	0.9m
Minimum ground clearance (collapsed state)	0.10m
Minimum ground clearance (Lifting state)	0.019m
Wheelbase	1.87m
Minimum radius of rotation	2.2m
Lifting motor	24V/4.5kw
Driving motor	24V/1.5kw
Machine travel speed (collapsed state)	4.0 km/h
Machine travel speed (Lifting state)	0.8 km/h
Lifting/Lower speed	80/60s
Battery	4 x 6V/280Ah
Charger	24V/30A
Max climb capability	25%
Maximum allowable working angel	1.5°/3°
Wheel	Φ381x127mm
Vehicle weight	2925kg
Maximum working pressure	240bar
<b>Airborne noise emissions</b>	
Sound pressure level at ground workstation	<70dBA
Sound pressure level atplatform workstation	<70dBA
<b>Ground bearing information</b>	
Maximum wheel load	1160kg
Local tire pressure	11.4kg/cm <sup>2</sup>
	1118.9kPa
Occupation pressure	1115kg/m <sup>2</sup>
	10.9kPa

## Specifications

### SC16E

Save working load	200kg
Extended platform Save working load	113kg
Maximum number of working people (indoor)	2
Maximum number of working people (outdoor)	/
Maximum working height(A)	15.7m
Maximum platform height(B)	13.7m
Vehicle length(C)	2.58m
Vehicle width(D)	1.25m
Vehicle height (fence not folded) (E)	2.58m
Vehicle height (fence folding)	2.17m
Platform dimension(length×width F)	2.64x1.02m
Platform extension dimension(G)	0.9m
Minimum ground clearance (collapsed state)	0.10m
Minimum ground clearance (Lifting state)	0.019m
Wheelbase	2.22m
Minimum radius of rotation	2.5m
Lifting motor	24V/4.5kw
Driving motor	24V/1.5kw
Machine travel speed (collapsed state)	3.2 km/h
Machine travel speed (Lifting state)	0.8 km/h
Lifting/Lower speed	70/52s
Battery	4 x 12V/310Ah
Charger	24V/30A
Max climb capability	25%
Maximum allowable working angel	1.5°/3°
Wheel	Φ381x127mm
Vehicle weight	2925kg
Maximum working pressure	240bar
Airborne noise emissions	
Sound pressure level atground workstation	<70dBA
Sound pressure level atplatform workstation	<70dBA
Ground bearing information	
Maximum wheel load	1160kg
Local tire pressure	11.4kg/cm <sup>2</sup> 1118.9kPa
Occupation pressure	1004kg/m <sup>2</sup> 9.84kPa

## Specifications

### SC08HN

Save working load	380kg
Extended platform Save working load	113kg
Maximum number of working people (indoor)	2
Maximum number of working people (outdoor)	1
Maximum working height(A)	8m
Maximum platform height(B)	6m
Vehicle length(C)	2.48m
Vehicle width(D)	0.81m
Vehicle height (fence not folded) (E)	2.24m
Vehicle height (fence folding)	1.81m
Platform dimension(length×width F)	2.27x0.81m
Platform extension dimension(G)	0.9m
Minimum ground clearance (collapsed state)	0.10m
Minimum ground clearance (Lifting state)	0.019m
Wheelbase	1.87m
Minimum radius of rotation	2.2m
Lifting/Driving motor	24V/3.3kw
Machine travel speed (collapsed state)	3.2 km/h
Machine travel speed (Lifting state)	0.8 km/h
Lifting/Lower speed	32/35s
Battery	4 x 6V/232Ah
Charger	24V/30A
Max climb capability	25%
Maximum allowable working angel	2°/3°
Wheel	Φ381x127mm
Vehicle weight	2160kg
Maximum working pressure	240bar
<b>Airborne noise emissions</b>	
Sound pressure level atground workstation	<70dBA
Sound pressure level at platform workstation	<70dBA
<b>Ground bearing information</b>	
Maximum wheel load	830kg
Local tire pressure	8.17kg/cm <sup>2</sup>
	800.6kPa
Occupation pressure	1105kg/m <sup>2</sup>
	10.8kPa

## Specifications

### SC10HN

Save working load	230kg
Extended platform Save working load	113kg
Maximum number of working people (indoor)	2
Maximum number of working people (outdoor)	0
Maximum working height(A)	10m
Maximum platform height(B)	8m
Vehicle length(C)	2.48m
Vehicle width(D)	0.81m
Vehicle height (fence not folded) (E)	2.36m
Vehicle height (fence folding)	1.93m
Platform dimension(length×width F)	2.27x0.81m
Platform extension dimension(G)	0.9m
Minimum ground clearance (collapsed state)	0.10m
Minimum ground clearance (Lifting state)	0.019m
Wheelbase	1.87m
Minimum radius of rotation	2.2m
Lifting/Driving motor	24V/3.3kw
Machine travel speed (collapsed state)	3.2 km/h
Machine travel speed (Lifting state)	0.8 km/h
Lifting/Lower speed	32/35s
Battery	4 x 6V/232Ah
Charger	24V/30A
Max climb capability	25%
Maximum allowable working angel	1.5°/3°
Wheel	Φ381x127mm
Vehicle weight	2275kg
Maximum working pressure	240bar
<b>Airborne noise emissions</b>	
Sound pressure level atground workstation	<70dBA
Sound pressure level atplatform workstation	<70dBA
<b>Ground bearing information</b>	
Maximum wheel load	830kg
Local tire pressure	8.17kg/cm <sup>2</sup>
	800.6kPa
Occupation pressure	1120kg/m <sup>2</sup>
	11kPa

## Specifications

### SC08EN

Save working load	380kg
Extended platform save working load	113kg
Maximum number of working people (indoor)	2
Maximum number of working people (outdoor)	1
Maximum working height(A)	8m
Maximum platform height(B)	6m
Vehicle length(C)	2.48m
Vehicle width(D)	0.81m
Vehicle height (fence not folded) (E)	2.24m
Vehicle height (fence folding)	1.81m
Platform dimension(length×width F)	2.27x0.81m
Platform extension dimension(G)	0.9m
Minimum ground clearance (collapsed state)	0.10m
Minimum ground clearance (Lifting state)	0.019m
Wheelbase	1.87m
Minimum radius of rotation (in/out)	2.2m
Lifting motor	24V/3.3kw
Driving motor	24V/1.5kw
Machine travel speed (collapsed state)	4.0 km/h
Machine travel speed (Lifting state)	0.8 km/h
Lifting/Lower speed	32/35s
Battery	4 x 6V/232Ah
Charger	24V/30A
Max climb capability	25%
Maximum allowable working angel	2°/3°
Wheel	Φ381x127mm
Vehicle weight	2160kg
Maximum working pressure	240bar
Airborne noise emissions	
Sound pressure level atground workstation	<70dBA
Sound pressure level atplatform workstation	<70dBA
Ground bearing information	
Maximum wheel load	830kg
Local tire pressure	8.17kg/cm <sup>2</sup> 800.6kPa
Occupation pressure	1135kg/m <sup>2</sup> 11.1kPa



## Specifications

### SC10EN

Save working load	230kg
Extended platform save working load	113kg
Maximum number of working people (indoor)	2
Maximum number of working people (outdoor)	0
Maximum working height(A)	10m
Maximum platform height(B)	8m
Vehicle length(C)	2.48m
Vehicle width(D)	0.81m
Vehicle height (fence not folded) (E)	2.36m
Vehicle height (fence folding)	1.93m
Platform dimension(length×width F)	2.27x0.81m
Platform extension dimension(G)	0.9m
Minimum ground clearance (collapsed state)	0.10m
Minimum ground clearance (Lifting state)	0.019m
Wheelbase	1.87m
Minimum radius of rotation (in/out)	2.2m
Lifting motor	24V/3.3kw
Driving motor	24V/1.5kw
Machine travel speed (collapsed state)	4.0 km/h
Machine travel speed (Lifting state)	0.8 km/h
Lifting/Lower speed	32/35s
Battery	4 x 6V/232Ah
Charger	24V/30A
Max climb capability	25%
Maximum allowable working angel	1.5°/3°
Wheel	Φ381x127mm
Vehicle weight	2275kg
Maximum working pressure	240bar
Airborne noise emissions	
Sound pressure level atground workstation	<70dBA
Sound pressure level atplatform workstation	<70dBA
Ground bearing information	
Maximum wheel load	830kg
Local tire pressure	8.17kg/cm <sup>2</sup> 800.6kPa
Occupation pressure	1150kg/m <sup>2</sup> 11.2kPa

## Operating Instructions

SC10H\SC12H\SC14H\SC16H\SC10E\SC12E\SC14E\SC16E\SC08HN\SC10HN\SC08EN  
\SC10EN

### Do Not Operate Unless:

You learn and practice the principles of safe machine operation contained in this operator's manual.

- 1 Avoid hazardous situations.
- 2 Always perform a pre-operation inspection.
- 3 Always perform function tests prior to use.
- 4 Inspect the workplace.
- 5 Only use the machine as it was intended.

### Fundamentals

The Operating Instructions section provides instructions for each aspect of machine operation. It is the operator's responsibility to follow all the safety rules and instructions in the operator's, safety and responsibilities manuals.

Using the machine for anything other than lifting personnel, along with their tools and materials, to an aerial work site is unsafe and dangerous.

Only trained and authorized personnel should be permitted to operate a machine. If more than one operator is expected to use a machine at different times in the same work shift, they must all be qualified operators and are all expected to follow all safety rules and instructions in the operator's, safety and responsibilities manuals. That means every new operator should perform a pre-operation inspection, function tests, and a workplace inspection before using the machine.

## Operating Instructions

### Emergency Stop

Push in the red Emergency Stop button to the off position at the ground controls or the platform controls to stop all functions. Repair any function that operates when either red Emergency Stop button is pushed in.

### Emergency Lowering

Pull the emergency lowering knob to lower the platform.

### Operation from Ground

- 1 Be sure the battery pack is connected before operating the machine.
- 2 Turn the key switch to ground control.
- 3 Pull out both ground and platform red Emergency Stop buttons to the on position.

#### To Position Platform

- 1 At the control panel, press and hold the lift function enable button.
- 2 Press the platform up or down button.

Drive and steer functions are not available from the ground controls.

### Operation from Platform

- 1 Be sure the battery pack is connected before operating the machine.
- 2 Turn the key switch to platform control.
- 3 Pull out both ground and platform red Emergency Stop buttons to the on position.

#### To Position Platform

- 1 Press the lift function button. On the LCD screen, a circle below the lift function symbol will turn on.

If the control handle is not moved within seven seconds of pushing the lift function button, the circle below the lift function symbol will turn off and lift function will not operate. Press the lift function button again.

- 2 Press and hold the function enable switch on the control handle.
- 3 Machines equipped with foot switch: Press and hold the foot switch and press and hold the function enable switch on the control handle at the same time.
- 4 Move the control handle according to the markings on the control panel.

## Operating Instructions

### To Steer

- 1 On the console of the workbench, press the drive or steering button, the button LED light up, said the machine is in the driving and steering state.
- 2 To make the device shift, should be according to the joystick handle by thumb operation rocker switch, right to turn right, left to turn left. When the switch is released, the switch will return to middle of the closed position, the wheel will remain in the previously selected position. To allow the wheel to return to the middle position, the switch must be moved in the opposite direction until the wheel is in the middle.



### To Drive

- 1 Rotate the key switch on the console in the (3) direction on the ground console.
- 2 The position of the emergency stop switch on the working table and the ground control console is set to the “open” position.
- 3 On the console of the workbench, press the drive or steering button, the button LED light up, said the machine is in the driving and steering state.
- 4 Press the joystick trigger switch of the front, and the lever can be moved forward, after the move can reverse. Drive system according to the proportion of work, to improve the speed of running, should be the steering lever from the middle position towards the driving direction. Release the trigger switch or return the joystick to the middle position to allow the machine to stop moving.

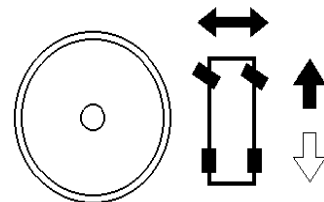
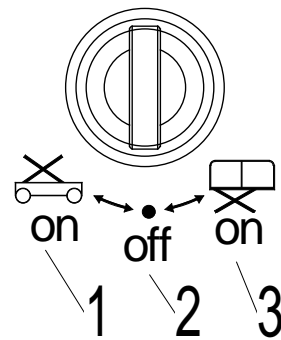

Use the color-coded direction arrows on the platform controls and on the platform to identify the direction the machine will travel.

Machine travel speed is restricted when the platform is raised.

Battery condition will affect machine performance. Machine drive speed and function speed will drop when the battery level indicator is flashing.

### Driving speed selection

The drive controller can operate in two different driving speed modes. When the drive speed select button light up, the slow speed mode is in the active state. When the drive speed select button go out, the fast speed mode is in the active state. Press the drive speed select button to select the desired drive speed.

## Operating Instructions

### Driving on a slope

Determine the slope and side slope ratings for the machine and determine the slope grade.

---

#### Maximum slope rating, stowed position:

---



SC10H\SC12H\SC14H\SC16H\SC10E\SC12E 25% 14°  
SC14E\SC16E\SC08HN\SC10HN\SC08EN\SC10EN

---

#### Maximum side slope rating, stowed position:

---

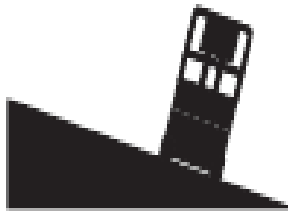

SC10H\SC12H\SC14H\SC16H\SC10E\SC12E 25% 14°  
SC14E\SC16E\SC08HN\SC10HN\SC08EN\SC10EN

---

**Note:** Slope rating is subject to ground conditions and adequate traction.  
Press the drive speed button to the fast drive speed mode.

## Operating Instructions

### To determine the slope grade:

Measure the slope with a digital inclinometer or use the following procedure.

You will need:

1. carpenter's level
2. straight piece of wood, at least 1 m long
3. tape measure

Lay the piece of wood on the slope.

At the downhill end, lay the level on the top edge of the piece of wood and lift the end until the piece of wood is level.

While holding the piece of wood level, measure the vertical distance from the bottom of the piece of wood to the ground.

Divide the tape measure distance (rise) by the length of the piece of wood (run) and multiply by 100.

Example:

Piece of wood = 3.6 m

Run = 3.6 m

Rise = 0.3 m

$0.3 \text{ m} \div 3.6 \text{ m} = 0.083 \times 100 = 8.3\% \text{ grade}$

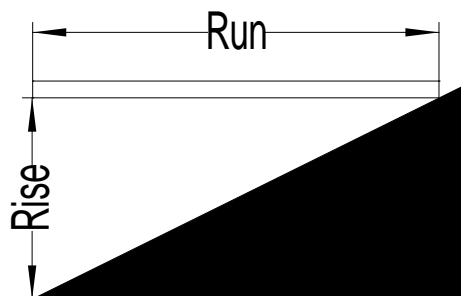

If the slope exceeds the maximum uphill, downhill or side slope rating, then the machine must be winched or transported up or down the slope. See Transport and Lifting section.

## Operating Instructions

### Operational indicator codes

If the platform controls LED or ground controls LCD diagnostic readout displays an operational indicator code such as LL, the fault condition must be repaired or removed before resuming machine operation. Push in and pull out the red Emergency Stop button to reset the system.

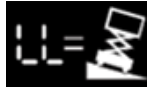

LED Readout



LCD Readout

For further information, please consult the schedule 1.

### Platform Overload

If the platform controls LED diagnostic readout displays a flashing OL and the ground controls LCD diagnostic readout displays OL:

Platform Overloaded, the platform is overloaded and no functions will operate. An alarm will sound.

- 1 Push in the Red Emergency stop button to the off position.
- 3 Remove weight from the platform.
- 3 Pull out the Red Emergency Stop button to the on position.

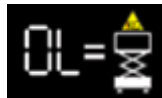

LED Readout



LCD Readout

## Operating Instructions

### Overload Recovery

If the ground controls LCD diagnostic readout displays Overload Recovery, the emergency lowering system has been used while the platform was overloaded. For information on how to reset this message, please consult the appropriate Noblelift Service Manual.







### Operation from Ground with Controller

Maintain safe distances between the operator, machine and fixed objects.  
Be aware of the direction the machine will travel when using the controller.

### Battery Level Indicator

Use the LED diagnostic readout to determine the battery level.

**Note:** When a blinking LO code appears on the platform controls LED display, the machine must be taken out of service and charged, otherwise all machine functions will be disabled.

Platform display	Quantity of electricity	Description
	90-100	Electricity is full
	70	Residual quantity of electricity
	50	Residual quantity of electricity
	30	Residual quantity of electricity
	20	Must charge
	10	Power is very low, the machine into the low speed



## Operating Instructions

### How to Use the Safety Arm

- 1 Raise the platform approximately 2.4 m from the ground.
- 2 Rotate the safety arm away from the machine and let it hang down.
- 3 Lower the platform until the safety arm rests securely on the link. Keep clear of the safety arm when lowering the platform.

### How to Fold Down the Guardrails

SC10H\SC12H\SC14H\SC16H\SC10E\SC12E\SC14E\SC16E\SC08HN\SC10HN\SC08EN  
\SC10EN

The platform railing system consists of three fold down rail sections for the extension deck and three sections for the main deck. All six sections are held in place by four wire lock pins.

- 1 Fully lower the platform and retract the platform extension.
- 2 Remove the platform controls.
- 3 From inside the platform, remove the two front wire lock pins.
- 4 Fold down the front rail assembly. Keep hands clear of pinch points.
- 5 Replace the two removed pins back into each side rail bracket.
- 6 Fold down each side rail assembly. Keep hands clear of pinch points.
- 7 At the rear of the main deck, remove the two wire lock pins.
- 8 Carefully open the gate and move to the ground.
- 9 Fold down the rear gate and entry side rails as one unit. Keep hands clear of pinch points.
- 10 Fold down the left and right side rails. Keep hands clear of pinch points.
- 11 Replace the two removed pins back into each side rail bracket.

### How to Raise the Guardrails

Follow the fold down instructions but in reverse order, ensuring all lock pins are in place and installed properly.

### After Each Use

- 1 Select a safe parking location—firm level surface, clear of obstruction and traffic.
- 2 Lower the platform.
- 3 Turn the key switch to the off position and remove the key to secure from unauthorized use.
- 4 Charge the batteries.

## Operating Instructions

### Battery and Charger Instructions

#### Observe and Obey:

- Do not use an external charger or booster battery.
- Charge the battery in a well-ventilated area.
- Use proper AC input voltage for charging as indicated on the charger.
- Use only a Noblelift authorized battery and charger.

#### To Charge Battery

- 1 Be sure the batteries are connected before charging the batteries.
- 2 Open the battery compartment. The compartment should remain open for the entire charging cycle.

#### Maintenance-free batteries

- 1 Connect the battery charger to a grounded AC circuit.
- 2 The charger will indicate when the battery is fully charged.

#### Standard Batteries

- 1 Remove the battery vent caps and check the battery acid level. If necessary, add only enough distilled water to cover the plates. Do not overfill prior to the charge cycle.
- 2 Replace the battery vent caps.
- 3 Connect the battery charger to a grounded AC circuit.
- 4 The charger will indicate when the battery is fully charged.
- 5 Check the battery acid level when the charging cycle is complete. Replenish with distilled water to the bottom of the fill tube. Do not overfill.

#### Dry Battery Filling and Charging Instructions

- 1 Remove the battery vent caps and permanently remove the plastic seal from the battery vent openings.
- 2 Fill each cell with battery acid (electrolyte) until the level is sufficient to cover the plates.

Do not fill to maximum level until the battery charge cycle is complete. Overfilling can cause the battery acid to overflow during charging. Neutralize battery acid spills with baking soda and water.

- 3 Install the battery vent caps.
- 4 Charge the battery.

Check the battery acid level when the charging cycle is complete. Replenish with distilled water to the bottom of the fill tube. Do not overfill.

## Transport and Lifting Instructions

### Observe and Obey:

Noblelift provides this securement information as a recommendation. Drivers are solely responsible for making sure machines are properly secured and the correct trailer is selected pursuant to US Department of Transportation regulations, other localized regulations, and their company policy.

Noblelift customers needing to containerize any lift or Noblelift product should source a qualified freight forwarder with expertise in preparing, loading and securing construction and lifting equipment for international shipment.

Only qualified aerial lift operators should move the machine on or off the truck.

The transport vehicle must be parked on a level surface.

The transport vehicle must be secured to prevent rolling while the machine is being loaded.

Be sure the vehicle capacity, loading surfaces and chains or straps are sufficient to withstand the machine weight. Noblelift lifts are very heavy relative to their size. See the serial label for the machine weight.

The machine must be on a level surface or secured before releasing the brakes.

Do not allow the rails to fall when the snap pins are removed. Maintain a firm grasp on the rails when the rails are lowered.

Do not drive the machine on a slope that exceeds the uphill, downhill or side slope rating. See Driving on a Slope in the Operating Instructions section.

If the slope of the transport vehicle bed exceeds the maximum slope rating, the machine must be loaded and unloaded using a winch as described in the brake release operation.

## Transport and Lifting Instructions

### Brake Release Operation

#### For hydraulic driven products

**(SC10H/SC12H/SC14H/SC16H/SC08HN/SC10HN)**

- 1 Chock the wheels to prevent the machine from rolling.
- 2 Be sure the winch line is properly secured to the drive chassis tie points and the path is clear of all obstructions.
- 3 Push in the black brake release knob to open the brake valve.
- 4 Pump the red brake release pump knob.

#### For motor driven products **(SC10E/SC12E/SC14E/SC16E/SC08EN/SC10EN)**

- 1 Chock the wheels to prevent the machine from rolling.
- 2 Pull out the red Emergency Stop button at both the ground and platform controls to the on position.
- 3 Down platform lift switches which on the ground controller, at the same time, the key switch to ground control side to release the brake.
- 4 If you need to reset the brakes, only need to turn off the key switch on the ground controller.

Towing the hydraulic driven machine is not recommended. If the machine must be towed, do not exceed 3.5km/h.

Towing the motor driven machine is not recommended. If the machine must be towed, do not exceed 4.1km/h.

## Transport and Lifting Instructions

### Securing to Truck or Trailer for Transit

- 1 Always use the extension deck lock when the machine is transported.
- 2 Turn the key switch to the off position and remove the key before transporting.
- 3 Inspect the entire machine for loose or unsecured items.
- 4 Use chains or straps of ample load capacity.
- 5 Use a minimum of 2 chains or straps.
- 6 Adjust the rigging to prevent damage to the chains.

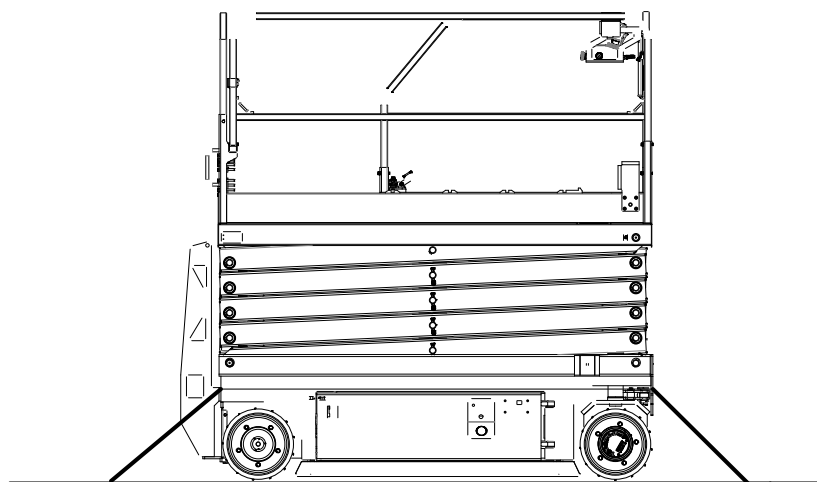
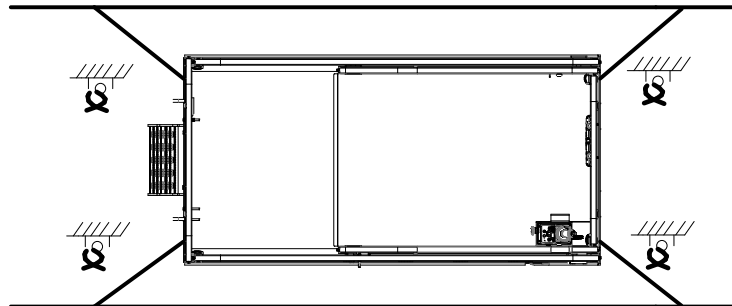

## Transport and Lifting Instructions



### Observe and Obey:

- Only qualified riggers should rig and lift the machine.
- Only qualified forklift operators should lift the machine with a forklift.
- Be sure the crane capacity, loading surfaces and straps or lines are sufficient to withstand the machine weight. See the serial label for the machine weight.

### Lifting the Machine with a Forklift

- ✓ Be sure the extension deck, controls and component trays are secure. Remove all loose items on the machine.
- ✓ Fully lower the platform. The platform must remain lowered during all loading and transport procedures.
- ✓ Use the forklift pockets located on both sides of the ladder.

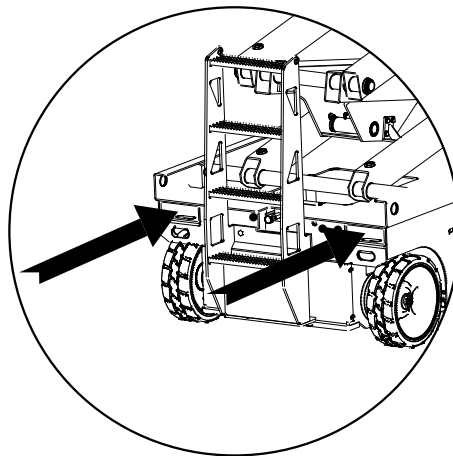

- ✓ Position the forklift forks in position with the forklift pockets.
- ✓ Drive forward to the full extent of the forks.
- ✓ Raise the machine 0.4 m and then tilt the forks back slightly to keep the machine secure.
- ✓ Lifting the machine from the side can result in component damage.

## NOTICE

Lifting the machine from the side can result in component damage.

## Transport and Lifting Instructions

### Lifting Instructions

- 1 Fully lower the platform. Be sure the extension deck, controls and component trays are secure. Remove all loose items on the machine.
- 2 Determine the center of gravity of your machine using the table and the picture on this page.
- 3 Attach the rigging only to the designated lifting points on the machine. There are two 2.5 cm holes on the front of the machine and two holes in the ladder for lifting.
- 4 Adjust the rigging to prevent damage to the machine and to keep the machine level.

### Center of Gravity Table

Model	X Axis	Y Axis
SC10H/SC10E	87.56cm	56.93cm
SC12H/SC12E	84.15cm	61.95cm
SC14H/SC14E	87.21cm	70.14cm
SC16H/SC16E	108.04cm	71.02cm
SC08HN/SC08EN	82.89cm	53.76cm
SC10HN/SC10EN	82.58cm	58.11cm

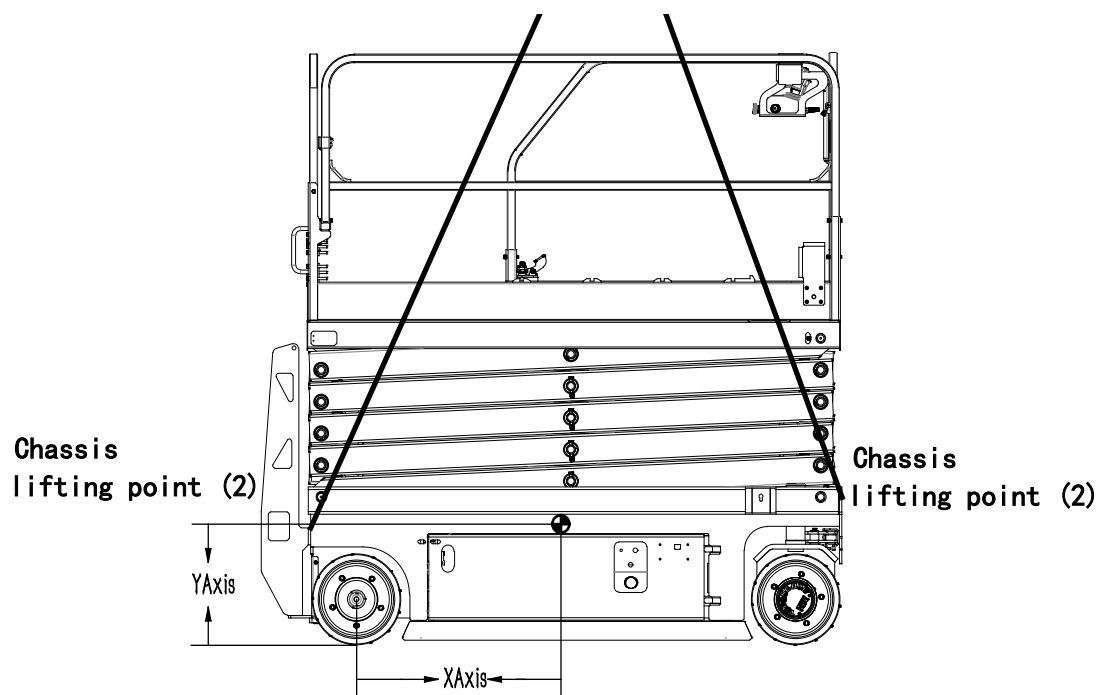

## Maintenance



### Observe and Obey:

- Only routine maintenance items specified in this manual shall be performed by the operator.
- Scheduled maintenance inspections shall be completed by qualified service technicians, according to the manufacturer's specifications and the requirements specified in the responsibilities manual.

### Maintenance Symbols Legend

**NOTICE** The following symbols have been used in this manual to help communicate the intent of the instructions. When one or more of the symbols appear at the beginning of a maintenance procedure, it conveys the meaning below.



Indicates that tools will be required to perform this procedure.



Indicates that new parts will be required to perform this procedure.



Indicates that dealer service will be required to perform this procedure.

### Pre-delivery Preparation Report

- 1 The pre-delivery preparation report contains checklists for each type of scheduled inspection.
- 2 Make copies for each inspection. Store completed forms as required.



## Maintenance

### Maintenance Schedule

A daily,quarterly,half yearly,every year and every two years and other five kinds of maintenance and inspection according to schedule.Product maintenance plan and pre delivery preparation report is divided into ABCDE five sub items.See the following table for each check.

Inspection	Checklist
Daily or every 8 hours	A
Quarterly or every 250 hours	A+B
Semi-annually or every 500 hours	A+B+C
Annually or every 1000 hours	A+B+C+D
Two-year or every 2000 hours	A+B+C+D+E

### Maintenance Inspection Report

Maintenance and inspection reports include all type of inspection items. Prepare the inspection for each inspection.At least 4 years after completion of the inspection,or in accordance with the law and regulations issued by the employer,the workplace and the government to implement.

## PRE-DELIVERY PREPARATION REPORT

### Fundamentals

- 1 It is the responsibility of the dealer to perform the Pre-delivery Preparation.
- 2 The Pre-delivery Preparation is performed prior to each delivery. The inspection is designed to discover if anything is apparently wrong with a machine before it is put into service.
- 3 A damaged or modified machine must never be used. If damage or any variation from factory delivered condition is discovered, the machine must be tagged and removed from service.
- 4 Repairs to the machine may only be made by a qualified service technician, according to the manufacturer's specifications.
- 5 Scheduled maintenance inspections shall be performed by qualified service technicians, according to the manufacturer's specifications and the requirements listed in the responsibilities manual.

## Maintenance

### Instructions

Use the operator's manual on your machine.

The Pre-delivery Preparation consists of completing the Pre-operation Inspection, the Maintenance items and the Function Tests.

Use this form to record the results. Place a check in the appropriate box after each part is completed. Follow the instructions in the operator's manual.

If any inspection receives an N, remove the machine from service, repair and re-inspect it. After repair, place a check in the R box.

---

### Legend

Y=yes, acceptable

N= no, remove from service

R= repaired

---

### Comments

<b>Pre-delivery Preparation</b>	<b>Y</b>	<b>N</b>	<b>R</b>
Pre-operation inspection completed			
Maintenance items completed			
Function tests completed			

---

**Model**

---

**Serial number**

---

**Date**

---

**Machine owner**

---

**Inspected by (print)**

---

**Inspector signature**

---

**Inspector title**

---

**Inspector company**

---

## Maintenance

### MAINTENANCE INSPECTION REPORT

---

**Model**

---

**Serial number**

---

**Date**

---

**Hour meter**

---

**Machine owner**

---

**Inspected by (print)**

---

**Inspector signature**

---

**Inspector title**

---

**Inspector company**

---

### Instructions

- Make copies of this report to use for each inspection.
- Select the appropriate checklist(s) for the type of inspection(s) to perform.

---

<input type="checkbox"/>	Daily or every 8 hours	A
<input type="checkbox"/>	Quarterly or every 250 hours	A+B
<input type="checkbox"/>	Semi-annually or every 500 hours	A+B+C
<input type="checkbox"/>	Annually or every 1000 hours	A+B+C+D
<input type="checkbox"/>	Two-year or every 2000 hours	A+B+C+D+E

---

- Place a check in the appropriate box after each inspection procedure is completed.
- Use the step-by-step procedures in this section to learn how to perform these inspections.
- If any inspection receives an "N," tag and remove the machine from service, repair and re-inspect it. After repair, place a check in the "R" box.

---

### Legend

Y = yes, acceptable

N = no, remove from service

R = repaired

---

## Maintenance

<b>Checklist A</b>	Y	N	R
A-1 Inspect the manuals and decals			
A-2 Pre-operation inspection			
A-3 Inspect the batteries			
A-4 Inspect the hydraulic oil level			
A-5 Function tests			
Perform after 40 hours:			
A-6 30-day service			
Perform after 100 hours:			
A-7 Grease steer yokes			

<b>Checklist B</b>	Y	N	R
B-1 Batteries			
B-2 Electrical wiring			
B-3 Tires and wheels			
B-4 Emergency stop			
B-5 Key switch			
B-6 Horn			
B-7 Drive brakes			
B-8 Drive speed-stowed			
B-9 Drive speed-raised			
B-10 Drive speed-slow			
B-11 Hydraulic oil analysis			
B-12 Tank venting system			
B-13 Chassis tray components			
B-14 Test down limit switch and pothole protection switches			
B-15 Test up limit switch			

## Maintenance

<b>Checklist C</b>	Y	N	R
C-1 Platform overload system			
C-2 Replace hydraulic oil tank vent pipe			

<b>Checklist D</b>	Y	N	R
D-1 Check scissor arm wear resistant slide block			
D-2 Replace hydraulic oil return filter			

<b>Checklist E</b>	Y	N	R
E-1 Hydraulic oil			

## Maintenance

### CHECKLIST A PROCEDURES

#### A-1

#### Inspect the Manuals and Decals

Maintaining the operator's and safety manuals in good condition is essential to safe machine operation. Manuals are included with each machine and should be stored in the container provided in the platform. An illegible or missing manual will not provide safety and operational information necessary for a safe operating condition.

In addition, maintaining all of the safety and instructional decals in good condition is mandatory for safe machine operation. Decals alert operators and personnel to the many possible hazards associated with using this machine. They also provide users with operation and maintenance information. An illegible decal will fail to alert personnel of a procedure or hazard and could result in unsafe operating conditions.

- 1 Check to make sure that the operator's and safety manuals are present and complete in the storage container on the platform.
- 2 Examine the pages of each manual to be sure that they are legible and in good condition.
  - ☉ Result: The operator's manual is appropriate for the machine and all manuals are legible and in good condition
  - ☐ Result: The operator's manual is not appropriate for the machine or all manuals are not in good condition or is illegible. Remove the machine from service until the manual is replaced.
- 3 Open the operator's manual to the decals inspection section. Carefully and thoroughly inspect all decals on the machine for legibility and damage.
  - ☉ Result: The machine is equipped with all required decals, and all decals are legible and in good condition.
  - ☐ Result: The machine is not equipped with all required decals, or one or more decals are illegible or in poor condition. Remove the machine from service until the decals are replaced.

## Maintenance

- 4 Always return the manuals to the storage container after use.

**NOTE:** Contact your authorized Noblelift distributor or Noblelift if replacement manuals or decals are needed

### A-2

#### Perform Pre-operation Inspection

Completing a Pre-operation Inspection is essential to safe machine operation. The Pre-operation Inspection is a visual inspection performed by the operator prior to each work shift. The inspection is designed to discover if anything is apparently wrong with a machine before the operator performs the function tests. The Pre-operation Inspection also serves to determine if routine maintenance procedures are required.

The complete inspection procedure may refer to the “Pre-operation Inspection” section of this manual.

### A-3

#### Inspect the Batteries



Good battery condition is essential to the performance and operation safety. Improper electrolyte level or damaged cables and wiring may cause damage to the parts and produce dangerous conditions.

**NOTE:** The installation of sealed batteries or maintenance free batteries, do not need to carry out this check.

**⚠ WARNING**      Electrocution hazard

Contact with electrically charged circuits could result in death or serious injury. Remove all rings, watches and other jewelry.

**⚠ WARNING**      Bodily injury hazard

Batteries contain acid. Avoid spilling or contacting battery acid. Neutralize battery acid spills with baking soda and water.

## Maintenance

**NOTE:**The following checks to be carried out in the case of sufficient battery power.

- 1 Wear protective clothing and wear protective glasses.
- 2 Ensure that the battery cable is firmly wired and not subject to corrosion.
- 3 Ensure the stability of the battery locking lever.
- 4 Take off the battery ventilation cover.
- 5 Check battery electrolyte level.If required,distilled water is added from the bottom of the storage battery.Do not add excess.
- 6 Put on the ventilation cover.

### A-4

#### Inspect the Hydraulic Oil Level



Maintaining the hydraulic oil at the proper level is essential to machine operation. Improper hydraulic oil levels can damage hydraulic components. Daily checks allow the inspector to identify changes in oil level that might indicate the presence of hydraulic system problems.

**NOTICE** The platform is in the implementation of this program under the collapsed state.

- 1 The level of visual inspection in the side of the hydraulic oil tank.
- ⊙ Result:Hydraulic oil should be placed at the mark of the oil tank.
- 2 On the need to refuel.Do not add excess.

#### Hydraulic oil specifications:

L-HL32 :For example,Northern China,Northern Europe and Russian; L-HM 46: For example,South China and Southeast Asia。 Special military and other requirements to replace the hydraulic oil.



## Maintenance

### A-5

#### Perform Function Tests

Completing the function tests is essential to safe machine operation. Function tests are designed to discover any malfunctions before the machine is put into service. A malfunctioning machine must never be used. If malfunctions are discovered, the machine must be tagged and removed from service.

The complete inspection procedure may refer to the “FunctionTests” section of this manual.

### A-6

#### Perform 30-Day Service



The 30-day maintenance procedure is a onetime procedure to be performed after the first 30 days or 40 hours of usage. After this interval, refer to the maintenance tables for continued scheduled maintenance.

Perform the following maintenance procedures:

- B-3 Tires and wheels
- D-2 Replace the hydraulic oil return filter

### A-7

#### Grease the Steer Yokes



This procedure be performed every 100 hours of operation.

Regular application of lubrication to the steer yokes is essential to good machine performance and service life. Continued use of an insufficiently greased steer yoke will result in component damage.

## Maintenance

- 1 Open the lid of the steer yokes.
- 2 At the top of the steer yokes, find the hole in the filling grease.
- 3 Fill in the steer yokes with enough grease until the grease is covered with a bearing.
- 4 Put back the lid.
- 5 Repeat the procedure for other steer yokes.

---

### Grease specification

---

Unified 3# universal grease

---

## Maintenance

### CHECKLIST B PROCEDURES

#### B-1

#### Inspect the Batteries



This procedure be performed every 250 hours or quarterly, whichever comes first.

Proper battery condition is essential to good machine performance and operational safety. Improper fluid levels or damaged cables and connections can result in component damage and hazardous conditions.

**⚠WARNING** Electrocutation hazard.

Contact with electrically charged circuits could result in death or serious injury. Remove all rings, watches and other jewelry.

**⚠WARNING** Bodily injury hazard.

Batteries contain acid. Avoid spilling or contacting battery acid. Neutralize battery acid spills with baking soda and water.

- 1 Put on protective clothing and eye wear.
- 2 Release the battery pack latch and rotate the battery pack out and away from the chassis
- 3 Be sure that the battery cable connections are free of corrosion.

**NOTE:** Adding terminal protectors and a corrosion preventative sealant will help eliminate corrosion on the battery terminals and cables.

- 4 Be sure that the battery retainers and cable connections are tight.
- 5 Fully charge the batteries. Allow the batteries to rest 24 hours before performing this procedure to allow the battery cells to equalize.

## Maintenance

### Models without maintenance-free or sealed batteries:

- 6 Remove the battery vent caps and check the specific gravity of each battery cell with a hydrometer. Note the results.
- 7 Check the ambient air temperature and adjust the specific gravity reading for each cell as follows:
  - Add 0.004 to the reading of each cell for every 10° / 5.5° C above 80° F / 26.7° C.
  - Subtract 0.004 from the reading of each cell for every 10° / 5.5° C below 80° F / 26.7° C.
- ⊙ Result: All battery cells display an adjusted specific gravity of 1.277 or higher. The battery is fully charged. Proceed to step 11.
- ⊘ Result: One or more battery cells display a specific gravity of 1.217 or below. Proceed to step 8.
- 8 Perform an equalizing charge OR fully charge the batteries and allow the batteries to rest at least 6 hours.
- 9 Remove the battery vent caps and check the specific gravity of each battery cell with a hydrometer. Note the results.
- 10 Check the ambient air temperature and adjust the specific gravity reading for each cell as follows:
  - Add 0.004 to the reading of each cell for every 10° / 5.5° C above 80° F / 26.7° C.
  - Subtract 0.004 from the reading of each cell for every 10° / 5.5° C below 80° F / 26.7° C.
- ⊙ Result: All battery cells display a specific gravity of 1.277 or greater. The battery is fully charged. Proceed to step 11.
- ⊘ Result: The difference in specific gravity readings between cells is greater than 0.1 OR the specific gravity of one or more cells is 1.217 or less. Replace the battery.
- 11 Check the battery acid level. If needed, replenish with distilled water to 1/8 inch / 3 mm below the bottom of the battery fill tube. Do not overfill.

## Maintenance

12 Install the vent caps and neutralize any electrolyte that may have spilled.

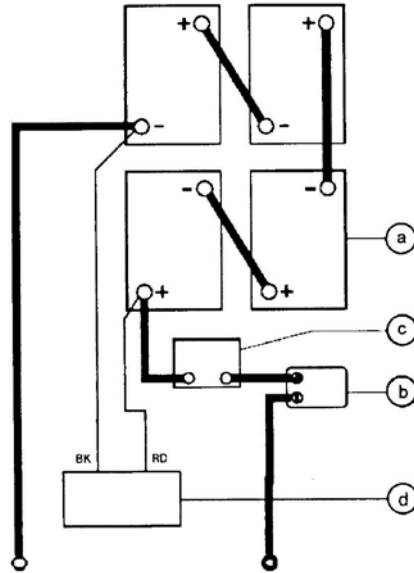

- a Battery
- b 300A fuse
- c Main power switch
- d Charger

### All models:

- 13 Check each battery pack and verify that the batteries are wired correctly.
- 14 Inspect the battery charger plug and pigtail for damage or excessive insulation wear. Replace as required.
- 15 Connect the battery charger to a properly grounded single phase AC power supply of 110-230V 50/60HZ.

- ⊙ Result: The charger should operate and begin charging the batteries.
- ⊠ Result: The charge's alarm sounded and the indicator light flashes, checking to correct the connection of the fuse and the charger. Make sure the charger is running normally, and start charging the battery.

**NOTE:** For best results, use an extension cord of adequate size with a length no longer than 50 feet / 15m.

## Maintenance

**NOTE:** If you have any further questions regarding the battery charger operation, please contact the Noblelift Scissor Service Department.

### B-2

#### Inspect the Electrical Wiring



This procedure be performed every 250 hours or quarterly, whichever comes first.

Maintaining electrical wiring in good condition is essential to safe operation and good machine performance. Failure to find and replace burnt, chafed, corroded or pinched wires could result in unsafe operating conditions and may cause component damage.



**WARNING** Electrocutation or explosion hazard

Contact with thermal or electrical conductor could result in death or serious injury. Remove all rings, watches and other jewelry.

- 1 Inspect the underside of the chassis for damaged or missing ground strap.
- 2 Inspect the following areas for burnt, chafed, corroded and loose wires:
  - Ground control panel
  - Hydraulic power unit module tray
  - Battery tray
  - Platform controls
- 3 Turn the key switch to ground control and pull out the red Emergency Stop button to the on position at both ground and platform controls
- 4 Raise the platform approximately 8 feet / 2.5 m from the ground.
- 5 Lift safety arm, mobile security arm to fork sleeve middle to rotate to the vertical state.
- 6 Lower the platform until the safety arm fully contact the shaft bushing.



**WARNING** Crushing hazard

## Maintenance

Keep hands clear of the safety arm when lowering the platform.

- 7 Inspect the center chassis area and scissor arms for burnt, chafed and pinched cables.
- 8 Inspect the following areas for burnt, chafed, corroded, pinched and loose wires:
  - Scissor arms
  - ECM to platform controls
  - Power to platform wiring
- 9 Inspect the free coating of insulating oil in the following position
  - Connect wiring harness connector between ECU and plane controller
  - All wire harness connectors for connecting level sensor
- 10 Raise the platform and return the safety arm to the stowed position.
- 11 Lower the platform to the stowed position and turn the machine off.

## B-3

### Inspect the Tires and Wheels



This procedure be performed every 250 hours or quarterly, whichever comes first.

Maintaining the tires and wheels in good condition is essential to safe operation and good performance. Tire and/or wheel failure could result in a machine tip-over. Component damage may also result if problems are not discovered and repaired in a timely fashion.

- 1 Check the tire surface and sidewalls for cuts, cracks, punctures and unusual wear.
- 2 Check each wheel for damage, bends and cracks.

## Maintenance

### Suitable for hydraulic driven models

- 3 Remove the cotter pin and check the castle nut for proper torque.

**NOTE:** Always replace the cotter pin with a new one when removing the castle nut or when checking the torque of the castle nut.

- 4 Install a new cotter pin. Bend the cotter pin to lock in place.

---

Non lubricated nut torque	406.7Nm
Lubricated nut torque	305Nm

---

### Suitable for electric driven models

3. Check all bolt torque

---

Non lubricated bolt torque	50.5Nm
Lubricated bolt torque	37.8Nm

---

## B-4

### Test the Emergency Stop

This procedure be performed every 250 hours or quarterly, whichever comes first.

A properly functioning Emergency Stop button is essential for safe machine operation. An improperly operating red Emergency Stop button will fail to shut off power and stop all machine functions, resulting in a hazardous situation.

As a safety feature, selecting and operating the ground controls will override the platform controls, except the platform red Emergency Stop button.

- 1 Turn the key switch to ground control and pull out the red Emergency Stop button to the on position at both the ground and platform controls.
- 2 Push in the red Emergency Stop button at the ground controls to the off position.



## Maintenance

- ⊙ Result: No machine functions should operate.
- 3 Turn the key switch to platform control and pull out the red Emergency Stop button to the on position at both the ground and platform controls.
- 4 Push down the red Emergency Stop button at the platform controls to the off position.
- ⊙ Result: No machine functions should operate.

**NOTE:** The red Emergency Stop button at the ground controls will stop all machine operation, even if the key is switched to platform control.

## B-5

### Test the Key Switch

This procedure be performed every 250 hours or quarterly, whichever comes first.

Proper key switch action and response is essential to safe machine operation. The machine can be operated from the ground or platform controls and the activation of one or the other is accomplished with the key switch. Failure of the key switch to activate the appropriate control panel could cause a hazardous operating situation.

Perform this procedure from the ground using the platform controls. Do not stand in the platform.

- 1 Pull out the red Emergency Stop button to the on position at both the ground and platform controls.
- 2 Turn the key switch to **platform controls**.
- 3 Check the platform up/down function from the **ground controls**.
- ⊙ Result: The machine functions should not operate.
- 4 Turn the key switch to **ground control**.
- ⊙ Result: The machine functions should not operate.

## Maintenance

5 Check the platform up/down function from the **platform controls**.

⊙ Result: The machine functions should not operate.

6 Turn the key switch to the off position.

⊙ Result: The machine functions should not operate.

### B-6

#### Test the Automotive-style Horn

This procedure be performed every 250 hours or quarterly, whichever comes first.

The horn is activated at the platform controls and sounds at the ground as a warning to ground personal. An improperly functioning horn will prevent the operator from alerting ground personal of hazards or unsafe conditions.

1 Turn the key switch to platform control and pull out the red Emergency Stop button to the on position at both the ground and platform controls.

2 Push down the horn button at the platform controls

⊙ Result: The horn should sound.

### B-7

#### Test the Drive Brakes



This procedure be performed every 250 hours or quarterly, whichever comes first.

Proper brake action is essential to safe machine operation. The drive brake function should operate smoothly, free of hesitation, jerking and unusual noise.

Hydraulically-released individual wheel brakes can appear to operate normally when not fully operational.

## Maintenance

Perform this procedure with the machine on a firm, level surface that is free of obstructions. Be sure the platform deck extension deck is fully retracted and the platform is in the stowed position.

- 1 Mark a test line on the ground for reference.
- 2 Turn the key switch to platform control and pull out the red Emergency Stop button to the on position at both the ground and platform controls.
- 3 Lower the platform to the stowed position.
- 4 Press the drive function selection button

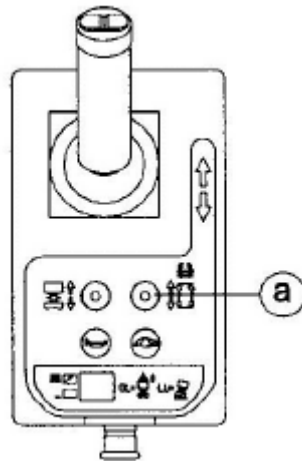

a The drive function selection button

- 5 Choose a point on the machine; i.e., contact patch of a tire, as a visual reference for use when crossing the test line.
  - 6 Bring the machine to top drive speed before reaching the test line. Release the drive/steer function enable switch or the joystick when your reference point on the machine crosses the test line.
  - 7 Measure the distance between the test line and your machine reference point.
- Result :The machine stops within the specified braking distance.Do not need any action.
- Result :The machine does not stop at the specified braking distance.

## Maintenance

**NOTE:** The brakes must be able to hold the machine on any slope it is able to climb.

- 8 Replace the brake, from 1 to repeat the above process.

---

### Maximum braking distance

---

Maximum braking distance	61cm±30cm
--------------------------	-----------

---

## B-8

### Test the Drive Speed - Platform Stowed



This procedure be performed every 250 hours or quarterly, whichever comes first.

Proper drive functions are essential to safe machine operation. The drive function should respond quickly and smoothly to operator control. Drive performance should also be free of hesitation, jerking and unusual noise over the entire proportionally controlled speed range.

Perform this procedure with the machine on a firm, level surface that is free of obstructions.

- 1 Create start and finish lines by marking two lines on the ground 40 feet / 12.2 m apart.
- 2 Turn the key switch to platform control and pull out the red Emergency Stop button to the on position at both the ground and platform controls.
- 3 Lower the platform to the stowed position.
- 4 Press the drive function selection button

## Maintenance

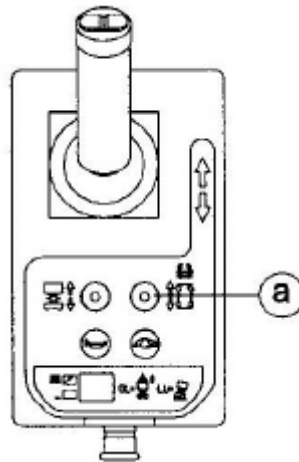

a The drive function selection button

- 5 Choose a point on the machine; i.e., contact patch of a tire, as a visual reference for use when crossing the test line.
- 6 Bring the machine to top drive speed before reaching the start line. Begin timing when the selected reference point on the machine crosses the start line.
- 7 Continue at full speed and note the time when your reference point on the machine passes the finish line. Refer to the *Specifications*.

## B-9

### Test the Drive Speed - Platform Raised



This procedure be performed every 250 hours or quarterly, whichever comes first.

Proper drive functions are essential to safe machine operation. The drive function should respond quickly and smoothly to operator control. Drive performance should also be free of hesitation, jerking and unusual noise over the entire proportionally controlled speed range.

Perform this procedure with the machine on a firm, level surface that is free of obstructions.

## Maintenance

- 1 Create start and finish lines by marking two lines on the ground 40 feet / 12.2 m apart.
- 2 Turn the key switch to platform control and pull out the red Emergency Stop button to the on position at both the ground and platform controls.
- 3 Press the platform up button.

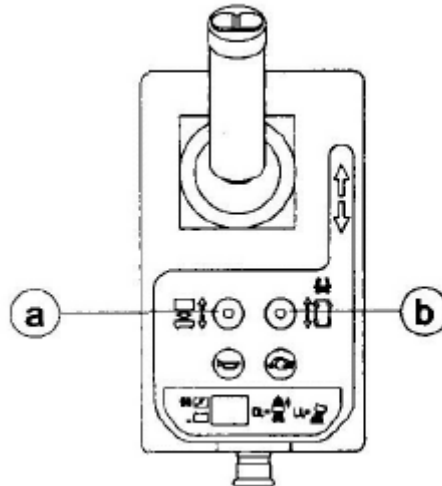

a The lift function selection button  
b The drive function button

- 4 Press the function enable button
- 5 Raise the platform approximately 7 feet/2 m from the ground.
- 6 Press the drive function selection button.
- 7 Choose a point on the machine; i.e., contact patch of a tire, as a visual reference for use when crossing the start and finish lines.
- 8 Bring the machine to top drive speed before reaching the start line. Begin timing when the selected reference point on the machine crosses the start line.
- 9 Continue at full speed and note the time when your reference point on the machine passes the finish line. Refer to the *Specifications*.

## Maintenance

### B-10

#### Test the Drive Speed - Slow



This procedure be performed every 250 hours or quarterly, whichever comes first.

Proper drive functions are essential to safe machine operation. The drive function should respond quickly and smoothly to operator control. Drive performance should also be free of hesitation, jerking and unusual noise over the entire proportionally controlled speed range.

Perform this procedure with the machine on a firm, level surface that is free of obstructions.

- 1 Create start and finish lines by marking two lines on the ground 40 feet / 12.2 m apart.
- 2 Turn the key switch to platform control and pull out the red Emergency Stop button to the on position at both the ground and platform controls.
- 3 Lower the platform to the stowed position.
- 4 Press the drive speed selection button.

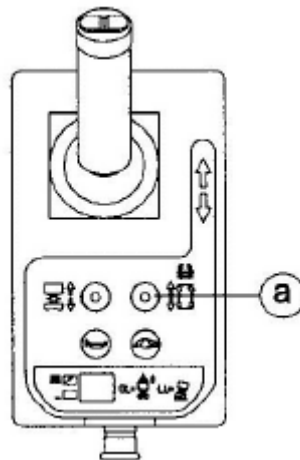

a The drive function selection button

## Maintenance

- 5 Choose a point on the machine; i.e., contact patch of a tire, as a visual reference for use when crossing the start and finish lines.
- 6 Bring the machine to top drive speed before reaching the start line. Begin timing when the selected reference point on the machine crosses the start line.
- 7 Continue at full speed and note the time when your reference point on the machine passes the finish line. Time is not less than 25 seconds.

### B-11

#### Perform Hydraulic Oil Analysis



This procedure be performed every 250 hours or quarterly, whichever comes first.

Replacement or testing of the hydraulic oil is essential for good machine performance and service life. Dirty oil may cause the machine to perform poorly and continued use may cause component damage. Extremely dirty conditions may require oil changes to be performed more often.

Before replacing the hydraulic oil, the oil may be tested by an oil distributor for specific levels of contamination to verify that changing the oil is necessary.

**If the hydraulic oil is not replaced at the two year inspection, test the oil quarterly. Replace the oil when it fails the test. See E-1, *Test or Replace the Hydraulic Oil*.**



## Maintenance

### B-12

#### Inspect the Hydraulic Tank Cap Venting System



This procedure be performed every 250 hours or quarterly, whichever comes first.

A free-breathing hydraulic tank cap is essential for good machine performance and service life. A dirty or clogged cap may cause the machine to perform poorly. Extremely dirty conditions may require that the cap be inspected more often.

1 Remove the breather cap from the hydraulic tank.

2 Check for proper venting.

☉ Result: Air passes through the breather cap.

☒ Result: If air does not pass through the cap, clean or replace the cap. Proceed to step 3.

**NOTE:** When checking for positive tank cap venting, air should pass freely through the cap.

3 Using a mild solvent, carefully wash the cap venting system. Dry using low pressure compressed air. Repeat step 2.

4 Install the breather cap onto the hydraulic tank.

### B-13

#### Check the Chassis Tray Latch Components



This procedure be performed every 250 hours or quarterly, whichever comes first.

## Maintenance

Maintaining the chassis tray latch components in good condition is essential to good performance and service life. Failure to detect worn out latch components may result in module trays opening unexpectedly, creating an unsafe operating condition.

- 1 Inspect each module tray rotary latch and related components for wear.
- 2 Using light oil, apply a few drops to each of the springs and to the sides of the rotary latch mechanism.

### B-14

#### Test the Down Limit Switch and Pothole Protection Switches



This procedure be performed every 250 hours or quarterly, whichever comes first.

Maintaining the limit switches is essential to safe operation and good machine performance. Operating the machine with a faulty limit switch could result in reduced machine performance and a potentially unsafe operating condition.

Perform this procedure with the machine on a firm, level surface that is free of obstructions.

#### Down Limit Switch

- 1 Remove the platform controls from the platform.
- 2 Raise the platform about 8 feet / 2.5 m.
- 3 Lift the safety arm, move it to the center of the scissor arm and rotate down to a vertical position.
- 4 Lower the platform until the safety arm fully contact the shaft bushing.



**WARNING** Crushing hazard

Keep hands clear of the safety arm when lowering the platform.

## Maintenance

- 5 Turn the key switch to the off position.
- 6 Tag and disconnect the platform control box at the platform.
- 7 Follow the platform control cable down the scissor stack to the alarm bracket on the chassis deck. Tag and disconnect the platform control cable from the ECM cable at the 6-pin Deutsch connector.
- 8 Securely install the platform control box harness plug into the 6-pin Deutsch connector of the ECM cable.
- 9 Disable the down limit switch. Loosen the fastener securing the roller arm to the limit switch, and rotate the roller arm 90 degrees in a downwards direction. Do not activate the switch contacts.
- 10 Turn the key switch to platform control.
- 11 Raise the platform and return the safety arm to the stowed position.
- 12 Working at the platform controls, press the lift function select button. Lower the platform to the stowed position.
  - ⊕ Result:Diagnostic display will display code 18,alarm sound,lifting function should be able to operate.Machine function is normal.
  - ⊖ Result:Diagnostic display will not display code 18,alarm does not sound,lifting function should not be able to operate.Limit switch to be replaced.
- 13 Press the drive function select button.Attempt to drive and steer the machine.
  - ⊕ Result:Diagnostic display will display code 18,alarm sound,steering and driving function can not be operated. Machine function is normal.
  - ⊖ Result:Diagnostic display will not display code 18,alarm does not sound, and steering and driving function can be operated. Limit switch to be replaced.
- 14 Press the platform up button. Raise the platform approximately 12 inches / 0.3 m.

## Maintenance

- ⊙ Result:Diagnostic display will display code 18,alarm sound,and lifting function can be operated. Machine function is normal.
  - ☒ Result:Diagnostic display will not display code 18,alarm does not sound. Limit switch to be replaced.
- 15 Up until the potholes protection device deployment platform.
- ⊙ Result:Diagnostic display will not display code 18,alarm does not sound.Machine function is normal.
  - ☒ Result:Diagnostic display will display code 18,alarm sound. Limit switch to be replaced.
- 16 Raise the platform about 8 feet/2.5m.
- 17 Lift the safety arm, move it to the center of the scissor arm and rotate down to a vertical position.
- 18 Lower the platform until the safety arm fully contact the shaft bushing.

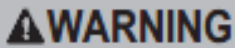

Collision hazard

Keep hands clear of the safety arm when lowering the platform.

- 19 Turn the key switch to the off position.
- 20 Disconnect the platform controls from the ECM cable.
- 21 Securely install the connector of the ECM cable into the platform control cable.
- 22 Connect the connector control platform.
- 23 Safety and correct connection limit switch of two lines.
- 24 Install lower limit switch box.
- 25 Turn the key switch to platform control.
- 26 Raise the platform and return the safety arm to the stowed position.

## Maintenance

27 Lower the platform to the stowed position.

### Pothole Protection Switches

28 Move the machine to the maximum tilt angle that is allowed by the level of the sensor. The maximum allowable inclination angle see nameplate.

29 Press the lifting function select button, the tilt of the ground up to about 7 feet/2m from the height of the ground.

- ⊙ Result: Diagnostic display will display code LL, alarm sound, the pothole protection device deployment. Machine function is normal.
- ☐ Result: Diagnostic display will not display code LL, alarm does not sound, the pothole protection device is not started. Adjust or replace the pothole protection switch.

30 Press the drive function select button, trying to drive a machine on a slope.

- ⊙ Result: Diagnostic display will display code LL, alarm sound, the steering and the driving function can not be operated. Machine function is normal.
- ☐ Result: Diagnostic display will not display code LL, alarm does not sound, the steering and the driving function can be operated. Adjust or replace the pothole protection switch.

31 Lower the platform to the stowed position. Move the machine onto a firm, level surface.

32 Place a wooden block approximately 2 inches / 5 cm tall under the right pothole guard.

33 Press the platform up button and attempt to raise the platform to approximately 8 feet / 2.4 m.

- ⊙ Result: Pothole protection device with wood, can not be fully expanded. Diagnostic display will not display code 18, alarm sound, the machine can rise to about 2m.
- ☐ Result: Pothole protection device with wood, can not be fully expanded. Diagnostic display will not display code 18, alarm does not sound, the machine can continue to rise. Machine function is normal. Adjust or replace the pothole protection limit switch.

## Maintenance

- 34 Press the drive function select button. Attempt to drive and steer the machine.
- ☉ Result: Diagnostic display will display code LL, alarm sound, the steering and the driving function can not be operated. Machine function is normal.
  - ☐ Result: Diagnostic display will not display code LL, alarm does not sound, the steering and the driving function can be operated. Adjust or replace the pothole protection switch.
- 35 Lower the platform to the stowed position and remove the block under the right pothole guard.
- 36 Repeat this procedure beginning with step 31 to 34 for the left pothole guard.
- 37 Lower the platform to the stowed position, remove the block under the left pothole guard.
- 38 Turn off the machine.

## B-15

### Test the Up Limit Switch



This procedure be performed every 250 hours or quarterly, whichever comes first.

Maintaining the limit switches is essential to safe operation and good machine performance. Operating the machine with a faulty limit switch could result in reduced machine performance and a potentially unsafe operating condition.

Perform this procedure with the machine on a firm, level surface that is free of obstructions.

- 1 Turn the key switch to ground control and raise the platform approximately 8 feet/2.5m from the ground.

## Maintenance

- 2 Rotate the safety arm away from the machine and let it hang down.
- 3 Lower the platform until the safety arm fully contact the shaft bushing.



Crushing hazard

Keep hands clear of the safety arm when lowering the platform.

- 4 Open the limit switch seat cover mounted on the chassis.
  - 5 A slight rise in the platform, to restore the safety arm.
  - 6 With the ground controller lifting platform at the same time by clicking the upper switch arm, active the up limit switch.
- ⊙ Result: The platform stops rising. The machine is functioning properly.
  - ⊗ Result: The platform continues to rise. Adjust or replace the up limit switch.

## CHECKLIST C PROCEDURES

### C-1

#### Test Platform Overload System



This inspection shall be carried out once every 500 hours or six months, whichever comes first. Check immediately when the machine is overloaded.

Testing the platform overload pressure transducer and platform height sensor regularly is essential to safe machine operation. Continued use of an improperly operating platform overload pressure transducer or platform height sensor, could result in the system not sensing an overloaded platform condition. Machine stability could be compromised resulting in the machine tipping over.

## Maintenance

Platform overload system is designed to prevent overload operation of the machine. It is made up of two electrical components: the overload pressure switch and the tilt sensor.

The overload pressure switch is adjustable, which is used to determine the pressure of the oil cylinder. When the pressure is too large, the pressure switch will send a signal to the ECU, all the functions of the machine to stop, until the excess load removed from the platform.

The tilt sensor, which is located in the inner shear fork arm 1, is used to measure the inclination angle of the scissors to determine the height of the platform.

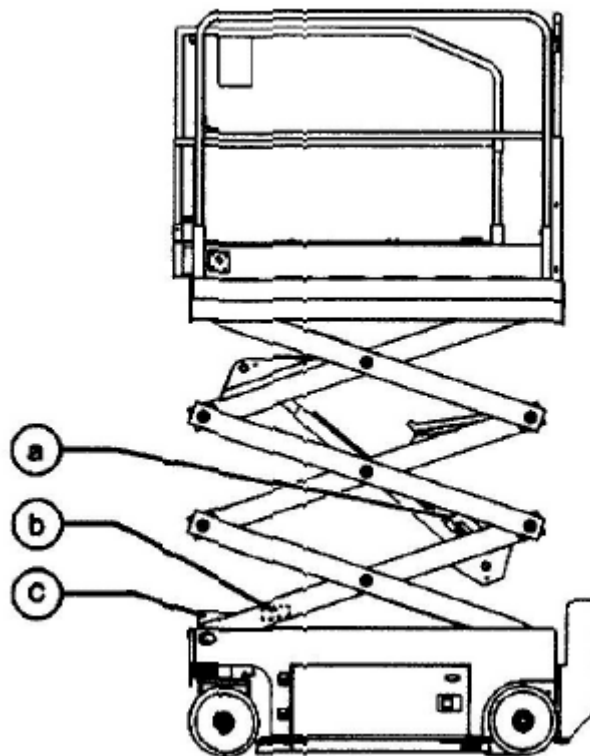

- a Overload pressure switch
- b Tilt sensor
- c Limit switch cover



## Maintenance

- 1 Turn the key switch to ground control, raising the platform to a height of about 8 feet/2.5m from the ground.
- 2 Lift the safety arm. Mobile security arm to fork sleeve middle to rotate to the vertical state.
- 3 Lower the platform until the safety arm fully contact the shaft bushing.

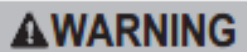

Crushing hazard

Keep hands clear of the safety arm when lowering the platform.

- 4 Open the limit switch seat cover mounted on the chassis.
- 5 Open the lid of the limit switch.

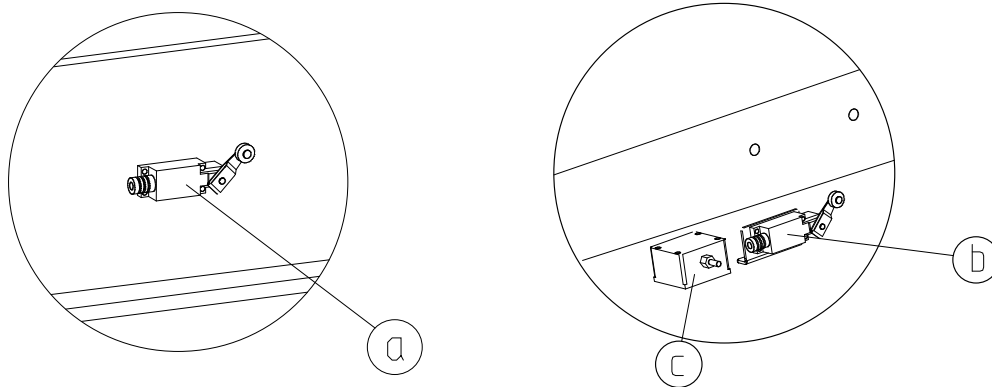

- a Up limit switch
- b Down limit switch
- c Tilt sensor

- 6 Mark and open the two lines of the upper limit switch.
- 7 The two lines that will be apart are connected together.
- 8 Turn the key switch to the ground control, and pull out two red emergency stop buttons for ground control and platform control.

## Maintenance

- 9 A slight rise in the platform,to restore the safety arm.
- 10 Lifting platform to the highest position,continue to press the function selection button.
  - ⊙ Result:Alarm sounds.
  - ☐ Result:Alarm does not sound.Calibration platform overload system.
- 11 Use auxiliary drop function to lower the platform to the stowed position
- 12 Carefully open the limit switch short circuit.
- 13 Lifting platform to the highest position,continue to press the function selection button.
  - ⊙ Result:Alarm does not sound.System function is normal.
  - ☐ Result:Alarm sounds,the platform overload system is not normal.
- 14 Down platform to about 8 feet/2.5 m from the ground.
- 15 Lift the safety arm.Mobile security arm to fork sleeve middle to rotate to the vertical state.
- 16 Lower the platform until the safety arm fully contact the shaft bushing.



Collision hazard

Keep hands clear of the safety arm when lowering the platform.

- 17 The limit switch is arranged as the original connection,and the limit switch cover is installed.
- 18 Put back limit switch cover.
- 19 Mounting platform limit switch seat cover.
- 20 A slight rise in the platform,to restore the safety arm.
- 21 Lower the platform to the stowed position

## Maintenance

### C-2

#### Replace Hydraulic Oil Tank Breather Cap



This inspection shall be carried out once every 500 hours or half a year, whichever comes first.

The hydraulic tank is a vented-type tank. The breather cap has an internal air filter that can become clogged or, over time, can deteriorate. If the breather cap is faulty or improperly installed, impurities can enter the hydraulic system which may cause component damage. Extremely dirty conditions may require that the cap be inspected more often.

- 1 Remove the hydraulic tank vent cover.
- 2 Replace the new hydraulic tank vent cover.

#### Checklist D Procedures

### D-1

#### Check the Wear Resistant Sliding Block



This inspection shall be carried out once every 1000 hours or year, whichever comes first.

The good or bad of the shear fork arm wear resisting sliding block is very important to the safe operation of the machine. The use of wear resistant block may cause damage to the parts of the work safety hazard.

## Maintenance

To check the wear pads on the platform under the collapsed state.

- 1 Measure the distance between the inner arm cross tube and the chassis deck at the ground controls side of the non-steer end of the machine.

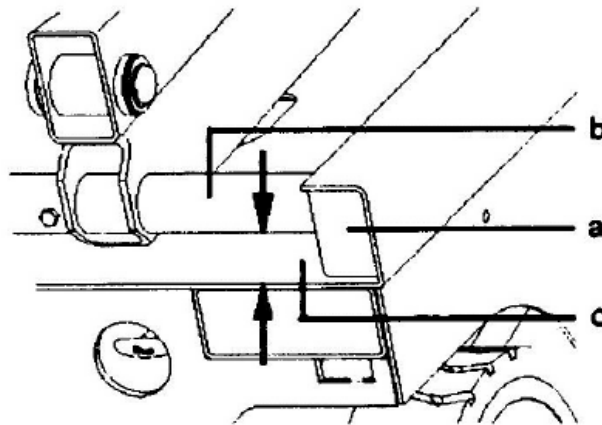

- a Wear resistant sliding block
- b Inner arm cross tube
- c Chassis deck

- ⊙ Result: The measurement is 13 inches / 34 mm or more. Proceed to step 2.
  - ⊘ Result: The measurement is less than 13 inches / 34 mm. Replace the wear resistant sliding block.
- 2 Measure the distance between the inner arm cross tube and the chassis deck at the battery pack side of the non-steer end of the machine.
    - ⊙ Result: The measurement is 13 inches / 34 mm or more. Proceed to step 3.
    - ⊘ Result: The measurement is less than 13 inches / 34 mm. Replace the wear resistant sliding block
  - 3 Spread the lubricant between the chassis rails and wear-resistant slider.

## Maintenance

### D-2

#### Replace the Hydraulic Tank Return Oil Filter Element



This inspection shall be carried out once every 1000 hours or year, whichever comes first.

Replacing the return oil filter is essential for good performance and service life of the machine. Dirty or blocked filter will affect the performance of the machine, continuous use will cause damage to the parts. Replacing the filter should be more frequent in the bad condition.

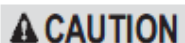

Burn hazard

Beware of hot oil. Contact with hot oil may cause severe burns.

Hydraulic oil tank return filter is mounted in the middle area of the function valve block and the hydraulic power unit.

- 1 Clean the area around the oil filter. Remove the filter with an oil filter wrench.
- 2 Apply a thin layer of oil to the new oil filter gasket.
- 3 Install the new filter and tighten it securely by hand.
- 4 Use a permanent ink marker to write the date and number of hours from the hour meter onto the filter.
- 5 Turn the key switch to ground control and pull out the red Emergency Stop button to the on position at both the ground and platform controls.
- 6 .Hold down and press down the function selection button.
- 7 Inspect the filter and related components to be sure that there are no leaks.
- 8 Clean up any oil that may have spilled.

## Maintenance

### CHECKLIST E PROCEDURES

#### E-1

#### Test or Replace the Hydraulic Oil



This inspection shall be carried out once every 2000 hours or two years, whichever comes first.

Replacement or testing of the hydraulic oil is essential for good machine performance and service life. Dirty oil may cause the machine to perform poorly and continued use may cause component damage. Extremely dirty conditions may require oil changes to be performed more often.

Before replacing the hydraulic oil, the oil may be tested by an oil distributor for specific levels of contamination to verify that changing the oil is necessary.

If the hydraulic oil is not replaced at the two year inspection, test the oil quarterly. Replace the oil when it fails the test.

**NOTE:** This procedure should be carried out in the stowed state machine.

- 1 Disconnect the battery pack from the machine.

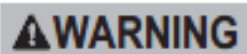

Electrocution/burn hazard.

Contact with electrically charged circuits could result in death or serious injury. Remove all rings, watches and other jewelry.

- 2 Open the power unit module tray.
- 3 Tag and disconnect the hydraulic tank return hard line from the hydraulic filter head and remove the hard line from the tank. Cap the fitting on the filter head.
- 4 Tag and disconnect the hydraulic pump inlet hard line and remove the hard line from the tank. Cap the fitting on the pump.

## Maintenance

- 5 Remove the hydraulic tank retaining fasteners and remove the hydraulic tank from the machine.
- 6 Discharge oil plug at the bottom of the hydraulic oil tank.
- 7 Drain all of the oil into a suitable container.



Bodily injury hazard

Spraying hydraulic oil can penetrate and burn skin. Loosen hydraulic connections very slowly to allow the oil pressure to dissipate gradually. Do not allow oil to squirt or spray.

- 8 Clean up any oil that may have spilled. Properly discard the used oil.
- 9 Clean the inside of the hydraulic tank using a mild solvent. Allow the tank to dry completely.
- 10 Tighten the oil drain plug. Torque to specification.

---

### Torque specification

---

Hydraulic oil tank drain plug, dry	4.5Nm
Hydraulic oil tank drain plug, lubricated	3.4Nm

---

- 11 Install the hydraulic tank and install and tighten the hydraulic tank retaining fasteners. Torque to specification.

---

### Torque specification

---

Hydraulic tank retaining fasteners, dry	4Nm
Hydraulic tank retaining fasteners, lubricated	2.9Nm

---

- 12 Install the hydraulic pump inlet hard line into the tank.
- 13 Install the hydraulic pump return hard line into the return oil filter.
- 14 Fill the tank with hydraulic oil until the fluid is at the full indicator on the hydraulic tank. Do not overfill.

## Maintenance

- 15 Activate the pump to fill the hydraulic system with oil and bleed the system of air.

**⚠ WARNING**

Component damage hazard

The pump can be damaged if operated without oil. Be careful not to empty the hydraulic tank while in the process of filling the hydraulic system. Do not allow the hydraulic pump appear turbid phenomenon.

### The Volume of Hydraulic Oil

Model	Hydraulic Oil Tank	Hydraulic System
SC10H/SC10E/SC08HN SC10HN/SC08EN/SC10EN	14L	20L
SC12H/SC12E	16L	25L
SC14H/SC14E	16L	25L
SC16H/SC16E	16L	25L



## Schematic Diagram

### Symbolic sample

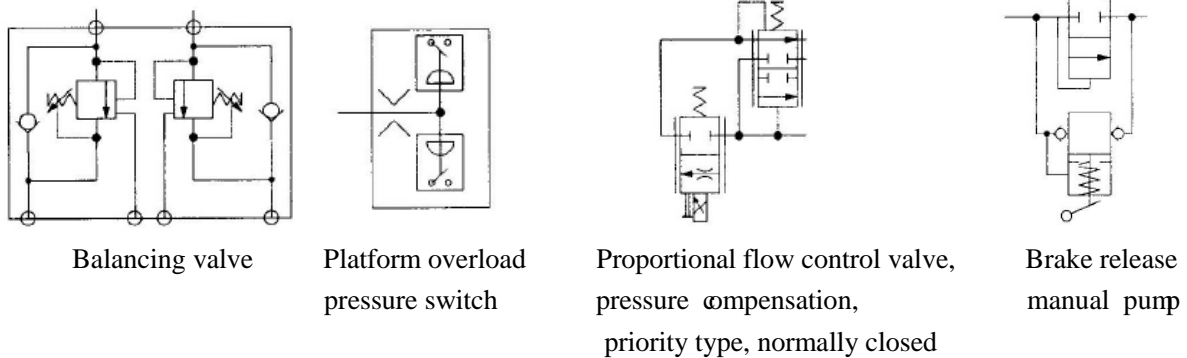
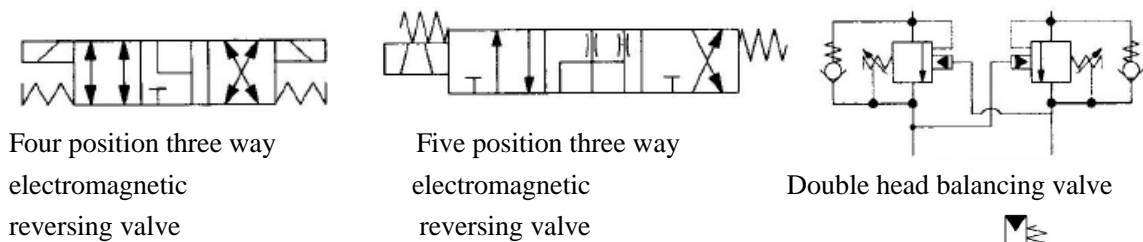
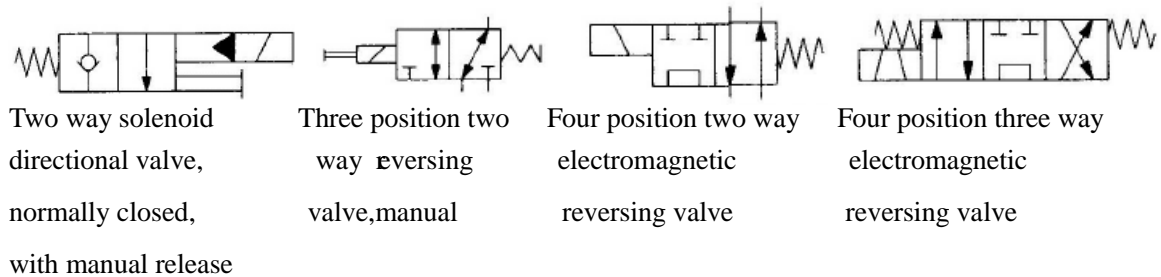
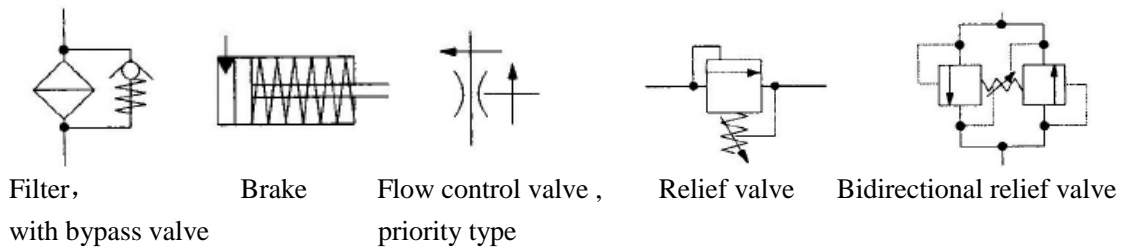
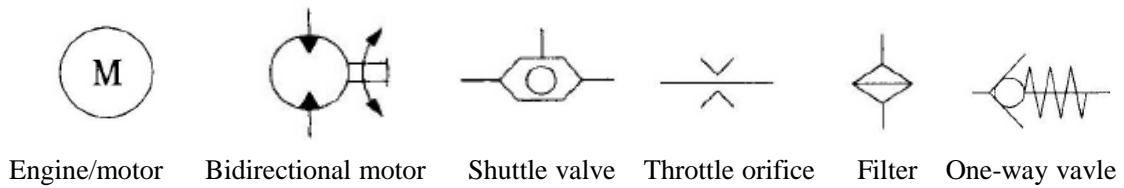
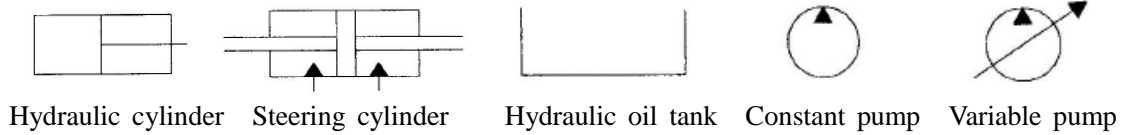

## Schematic diagram

### Hydraulic schematic diagram

### SC10H/SC08HN/SC10HN

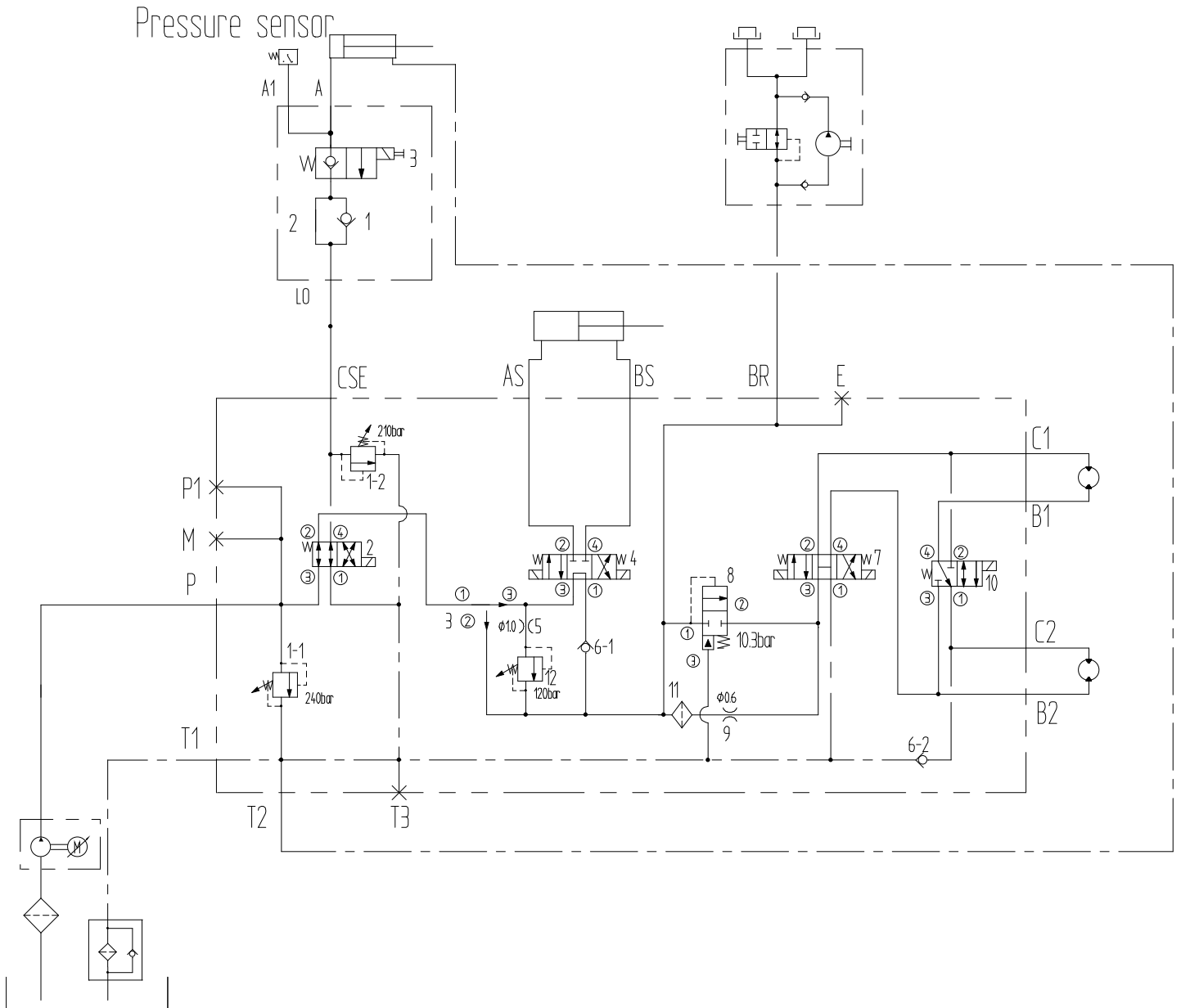

## Schematic diagram

### SC12H/SC14H/SC16H

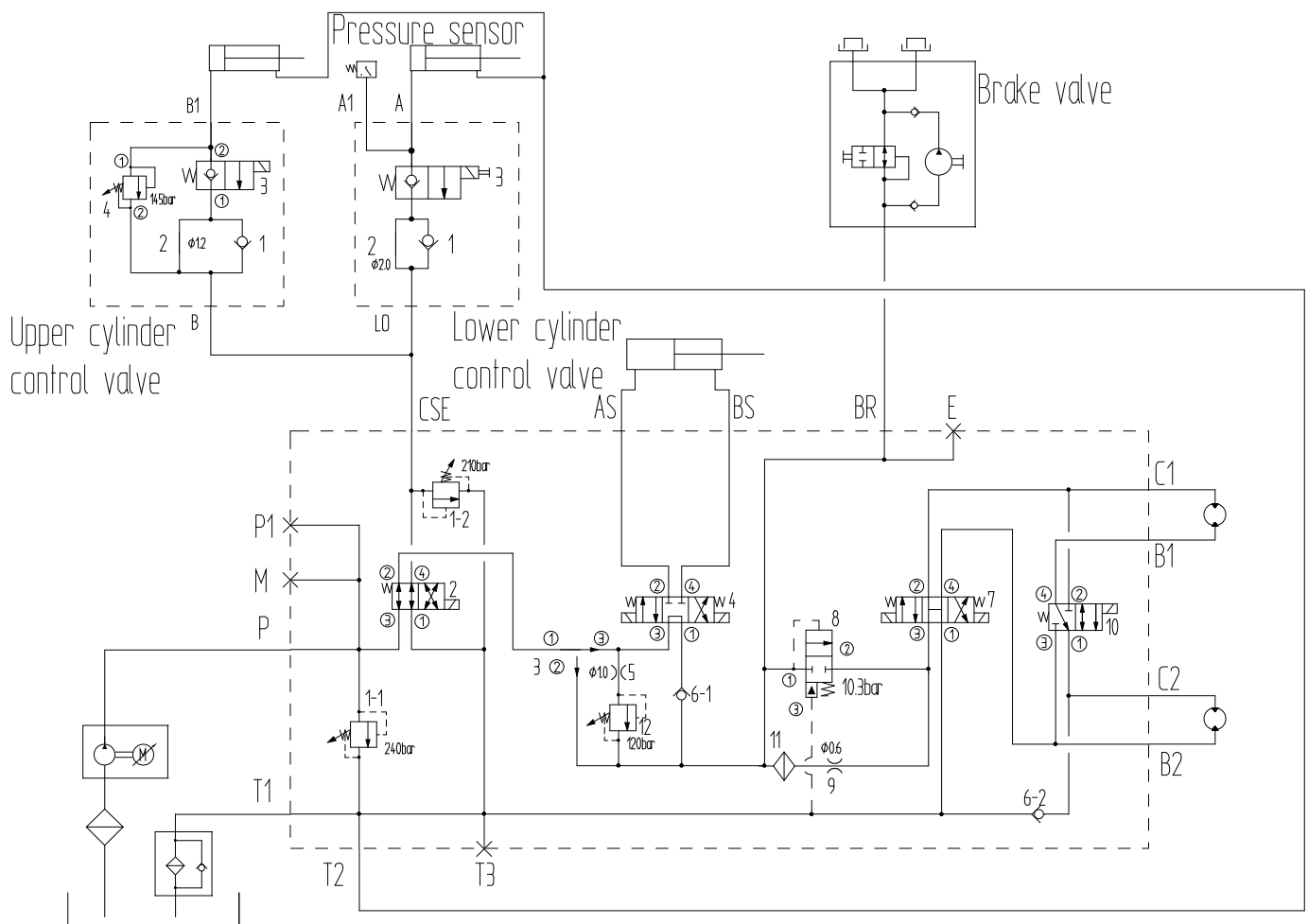

## Schematic diagram

### SC10E/SC08EN/SC10EN

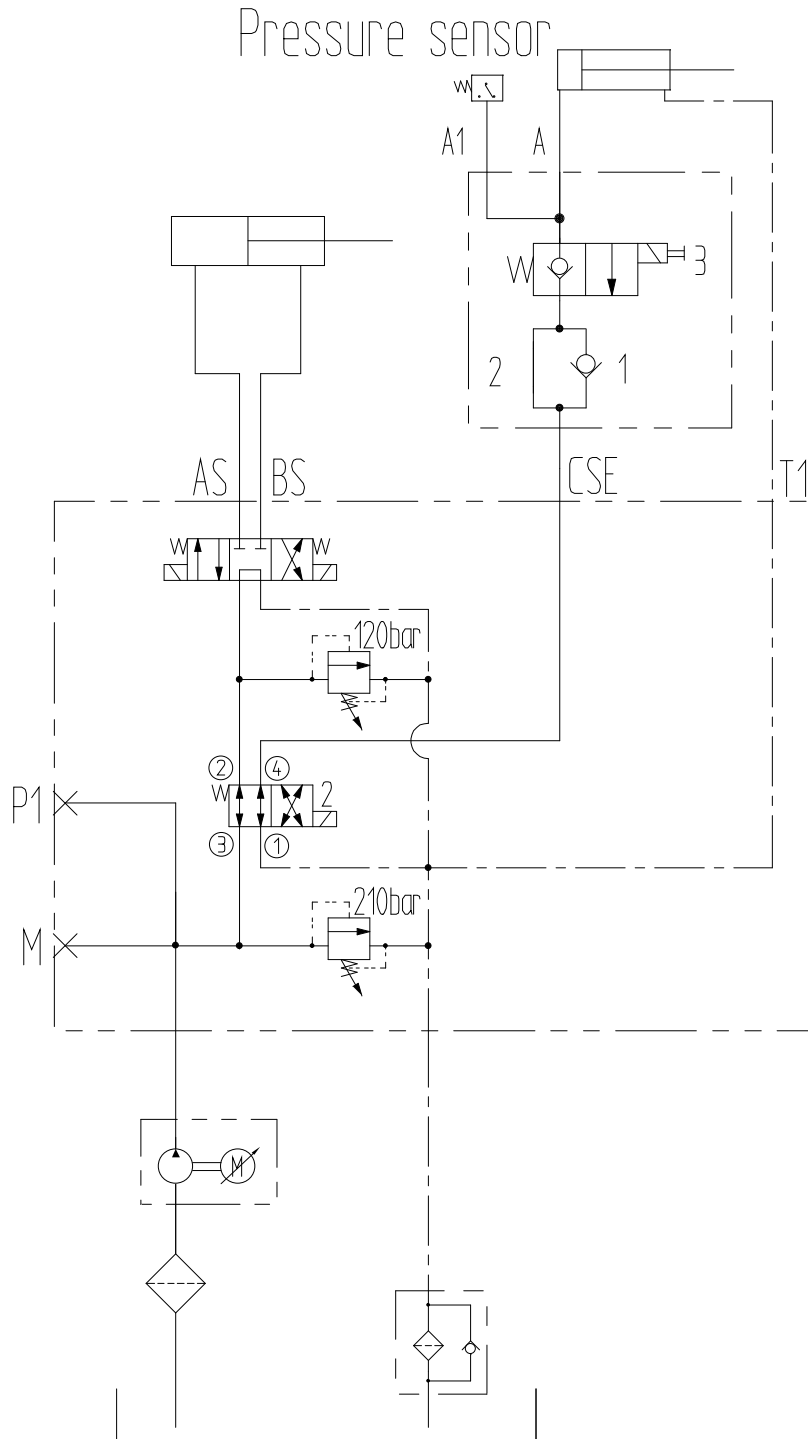

## Schematic diagram

SC12E/SC14E/SC16E

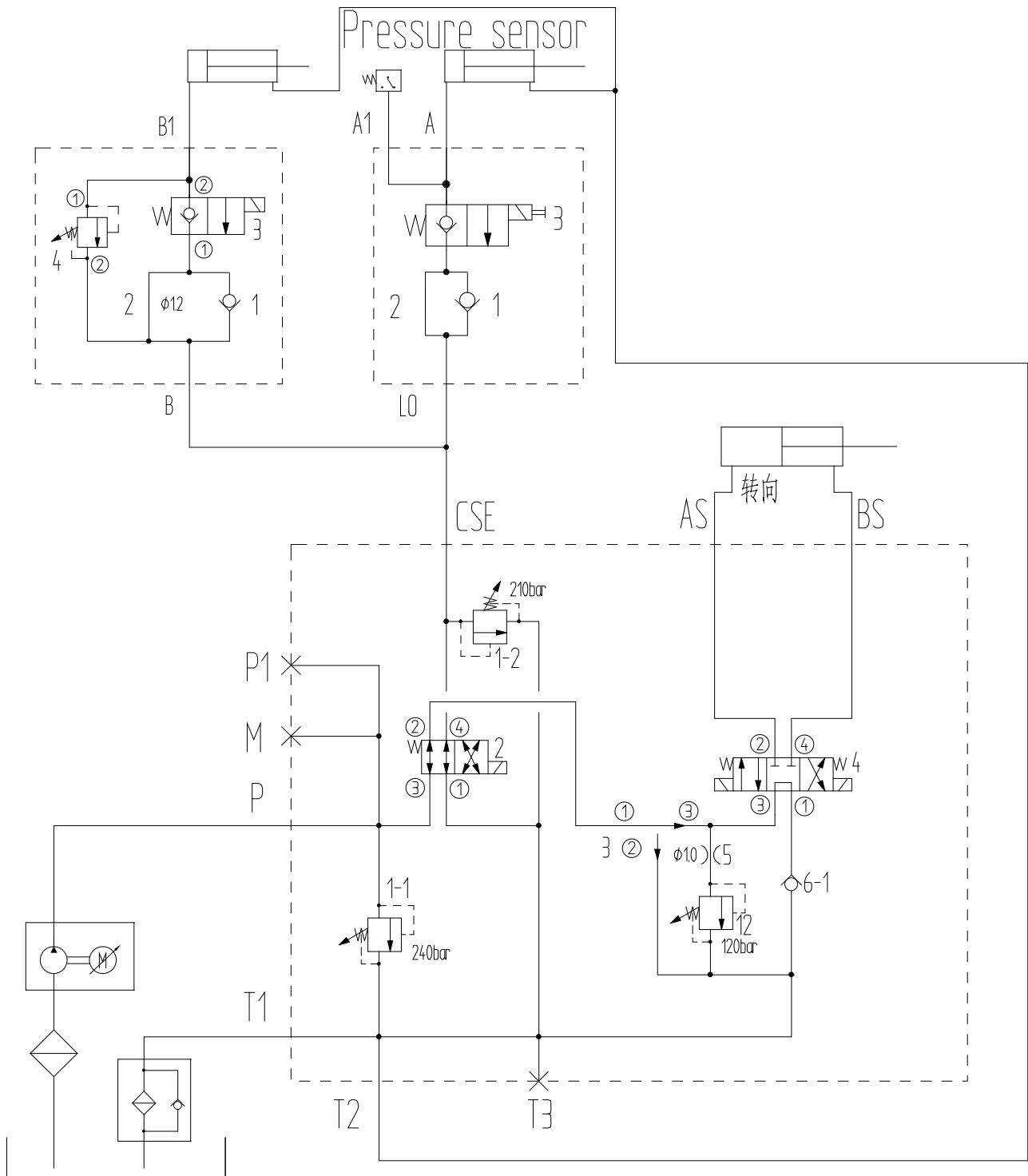

# Schematic diagram

## Electrical schematic diagram

### SC10H/SC08HN/SC10HN

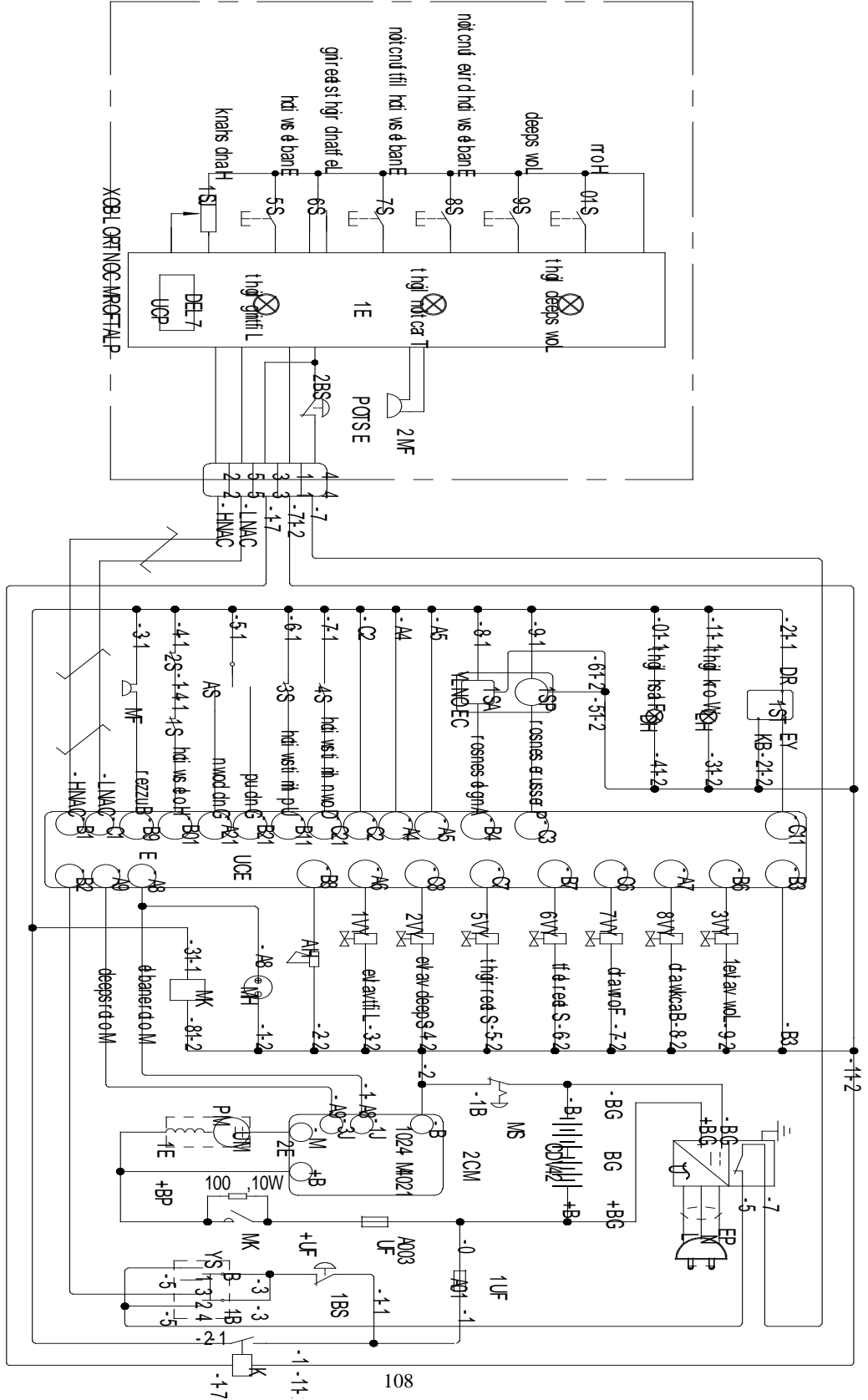

## Schematic diagram

### SC12H/SC14H/SC16H

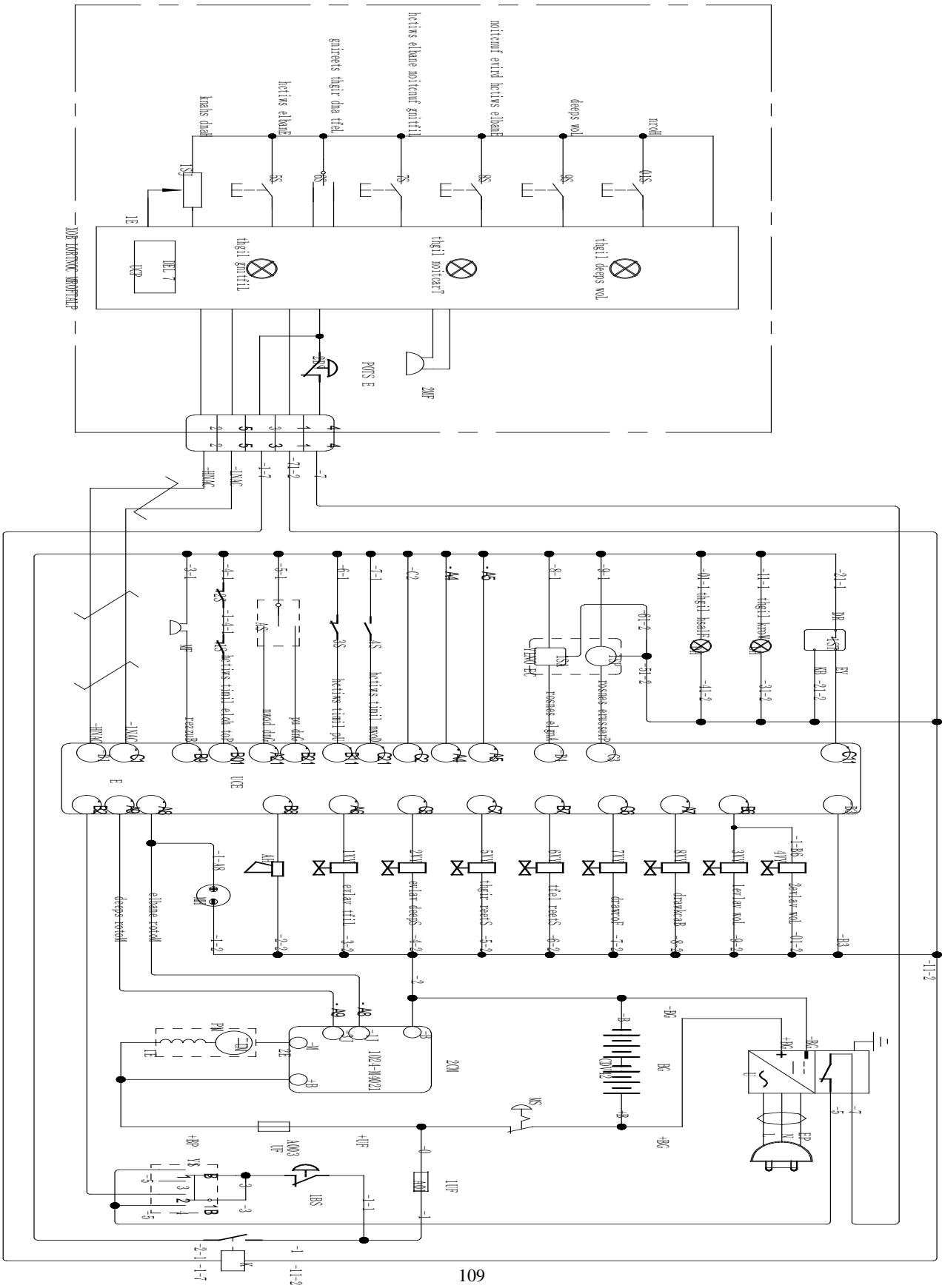

**Schematic diagram**

**SC10E/SC08EN/SC10EN**

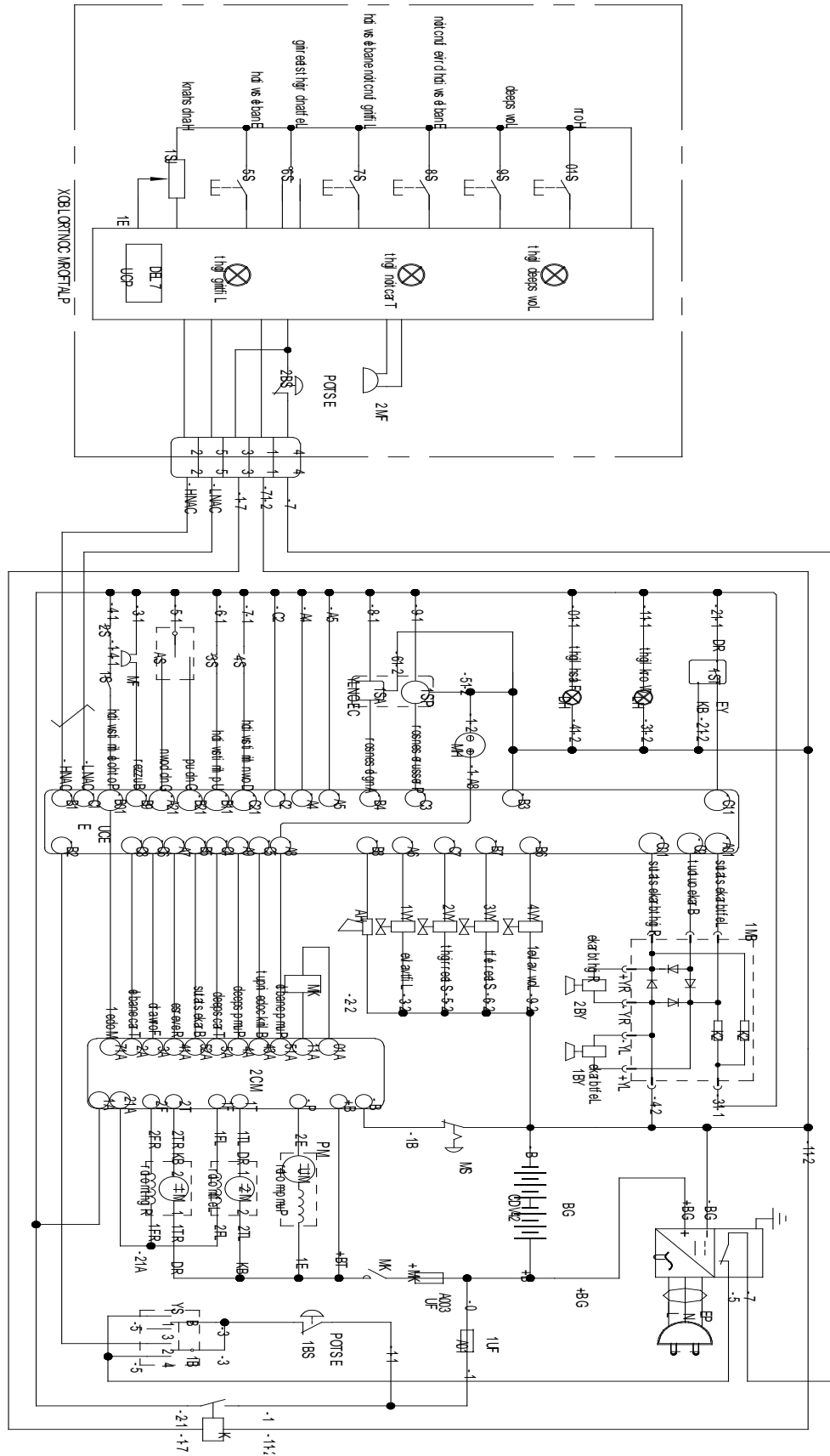



## Schematic diagram

### SC12E/SC14E/SC16E

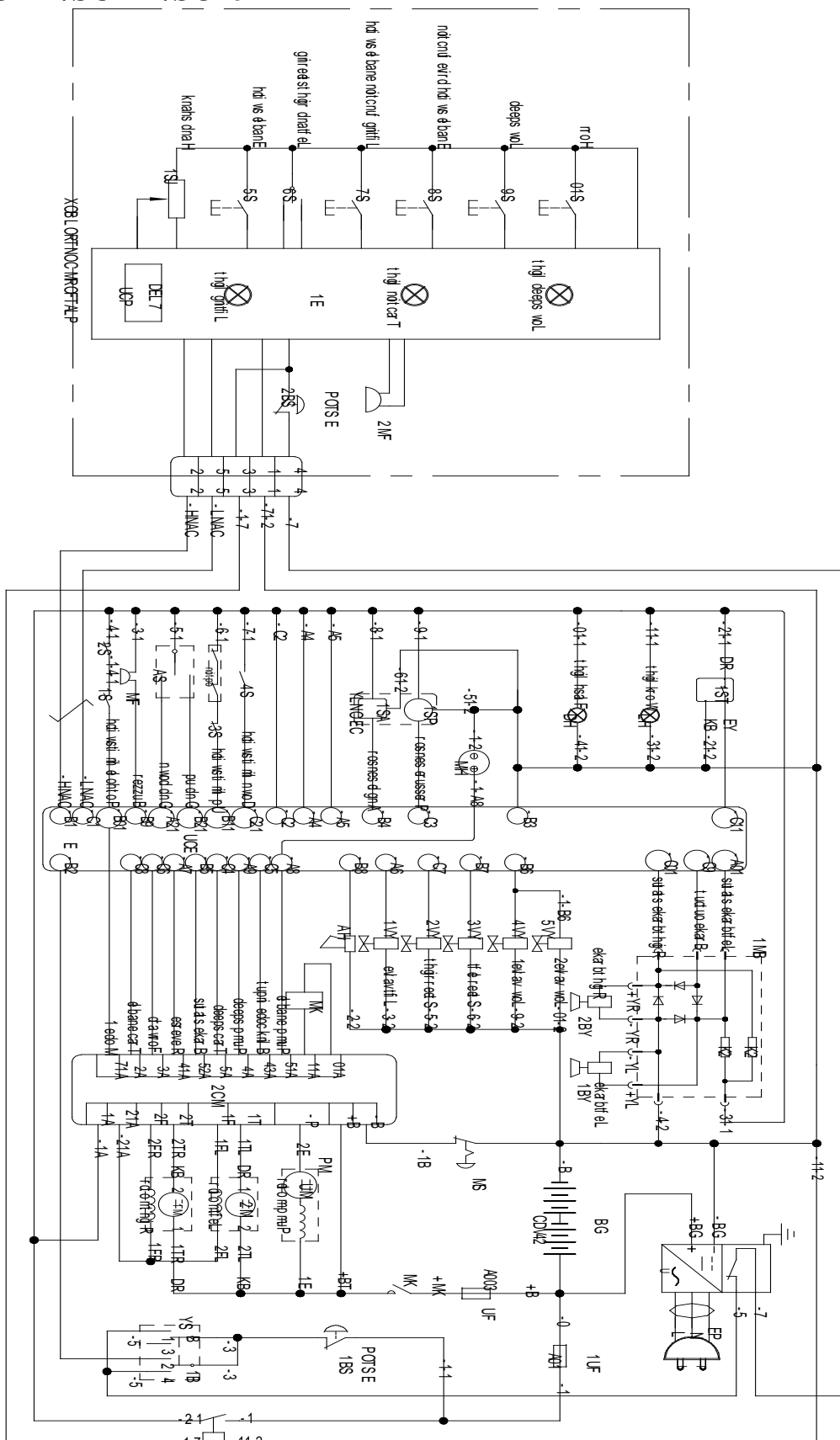

## Schedule 1 Fault Code

Display	describe	The machine response	The solution to guide
01	As seen on ECU, System initialization Fault, see also 10	Disables All Motion	ECU may be malfunctioning, replace it.
02	As seen on ECU, System communication Fault, see 20	Disables All Motion	Check communications cable connections and other wiring. If that does not resolve the problem, try replacing the PCU or ECU.
03	Invalid option setting Fault	Disables All Motion	Set appropriate option for this lift.
10	As seen on PCU, System initialization Fault, see also 01	Disables All Motion	ECU may be malfunctioning, replace it.
12	Chassis Up or Down Switch ON at power-up Fault	Disable Chassis Control	Check the wires to the Toggle Switch or look for a stuck Toggle Switch.
18	Pothole Guard Fault	Disable Lifting and Driving	Check that the pothole guards are extended, check the pothole limit switches. Check wires to the switches, check the down limit switch and connections.
20	As seen on PCU, System communication Fault, see 02	Disables All Motion	Check communications cable connections and other wiring. If that does not resolve the problem, try replacing the PCU or ECU.
31	Pressure Sensor Fault	Disables All Motion	Check the wiring to the sensor and then the sensor itself. Also check to make sure that the correct option is properly selected (or not) for load sensing.
32	Angle Sensor Fault	Disables All Motion	Check the wiring to the sensor and then the sensor itself. Also check to make sure that the correct option is properly selected (or not) for load sensing
36	Battery Low Fault	Disables Drive Fast and Lifting Functions	Check voltage on the batteries and for loose connections in the power supply cabling.
42	Platform Left Turn Switch ON at power-up Message	Diagnostic Message Only	Ensure that nothing is holding the Joystick Toggle Switches down. If OK, consider replacing the Joystick or PCU.
43	Platform Right Turn Switch ON at power-up Message	Diagnostic Message Only	Ensure that nothing is holding the Joystick Toggle Switches down. If OK, consider replacing the Joystick or PCU.
46	Platform Joystick Enable Switch ON at power-up Fault	Disable Platform Control	Ensure that nothing is holding the Enable switch closed. Also check the neutral zone parameters. If OK, consider replacing the Joystick or PCU.

47	Platform Joystick not in neutral at power-up Message	Diagnostic Message Only	Make sure that the Joystick is in the neutral (upright) position. Check the neutral zone parameter setting in Dingli Scissor Programmer. If it's OK, consider replacing the Joystick or the PCU.
52	Go forward Coil Fault	Disable Lifting and Driving	Check the connections to the Coil's terminals and make sure they are tight. If so, check the coil itself to see if it is open or shorted.
53	Back off Coil Fault	Disable Lifting and Driving	Check the connections to the Coil's terminals and make sure they are tight. If so, check the coil itself to see if it is open or shorted.
54	Lift Up Coil Fault	Disable Lifting and Driving	Check the connections to the Coil's terminals and make sure they are tight. If so, check the coil itself to see if it is open or shorted.
55	Lift Down Coil Fault	Disable Lifting and Driving	Check the connections to the Coil's terminals and make sure they are tight. If so, check the coil itself to see if it is open or shorted.
56	Right Turn Coil Fault	Disable Lifting and Driving	Check the connections to the Coil's terminals and make sure they are tight. If so, check the coil itself to see if it is open or shorted.
57	Left Turn Coil Fault	Disable Lifting and Driving	Check the connections to the Coil's terminals and make sure they are tight. If so, check the coil itself to see if it is open or shorted.
58	Brake Coil Fault	Disable Lifting and Driving	Check the connections to the Coil's terminals and make sure they are tight. If so, check the coil itself to see if it is open or shorted.
59	Associated Valve Coil Fault	Disable Lifting and Driving	Check the connections to the Coil's terminals and make sure they are tight. If so, check the coil itself to see if it is open or shorted.
61	Motor Controller Current Sensor Fault	Controller Dependent	Drive or Lift Motor may be overheating. Let the lift cool down. If that does not help, cycle power to reset the Motor controller. If the problem persists, check the wiring and if OK, try replacing the Motor Controller.
62	Motor Controller Hardware or Software Fault	Controller Dependent	Cycle power. If that does not resolve the issue check for noise sources. If still needed, try replacing the Motor Controller.
63	Motor Controller Motor Output Fault	Controller Dependent	Check wiring first then cycle power. If needed replace controller.

64	Motor Controller SRO Fault	Controller Dependent	Look at motor enable delay with the NOBLELIFT Scissor Programmer, it may be too short. Make sure other Motor Controller parameters are properly selected.
65	Motor Controller Throttle Fault	Controller Dependent	Check wiring. Make sure the correct throttle type is selected in the Motor Controller.
66	Motor Controller Emergency Reverse Fault	Controller Dependent	Ensure that the Emergency Reverse Check parameter is off in the Motor Controller.
67	Motor Controller HPD Fault	Controller Dependent	Look at motor enable delay with the NOBLELIFT Scissor Programmer, it may be too short. Make sure other Motor Controller parameters are properly selected.
68	Unsafe Power Conditions or Interruptions	Disables All Motion	Check battery voltage and charge batteries if necessary. Check the battery connections and tighten or clean. Check the voltage to the ECU and PCU.
69	High Neutral Current Fault	Disables All Motion	The MC is sensing current in the motors when there should not be. This could occur anytime the MC thinks the brakes are on and the motors are still turning. This message can be ignored when it comes immediately before other faults.
70	Steer Input Out of Range	Disables All Motion	There is an inappropriate voltage at the steering input of the ZAPI motor controller. The ZAPI may need to be "trained" for the three steering voltages (on Differential Steered machines). Or the steering voltage from the ECU was at some point outside of the range that was recorded during the "training" session. Retrain the ZAPI and/or check for fluctuating voltages due to loose wires, etc.
71	Motor Controller Main Contactor or Pump Motor Short	Disable Lifting and Driving	Check the connections to the main contactor. Replace the contactor if necessary. Replace the Motor Controller if necessary.
72	Motor Controller Over Voltage Fault	Controller Dependent	Check battery voltage and make sure the battery charger is not on. Then cycle power to the lift. If that does not resolve the issue, try replacing the Motor Controller.
73	Motor Controller Thermal Cutback Fault	Controller Dependent	Drive or Lift Motor may be overheating. Let the lift cool down. If that does not help cycle power to reset the Motor controller. If that doesn't resolve the issue, replace the Motor Controller.
74	Motor Controller Motor Fault	Controller Dependent	Check connections to the motors. Cycle power to the lift and if that does not resolve the issue, replace the Motor Controller.

75	Motor Controller Pump Motor Fault, ZAPI = Open	Controller Dependent	Check connections to the Pump Motor. Cycle power to the lift and if that does not resolve the issue, replace the Motor Controller.
76	Motor Controller Left Drive Motor Fault, ZAPI = Open	Controller Dependent	Check connections to the motors. Cycle power to the lift and if that does not resolve the issue, replace the Motor Controller.
77	Motor Controller Right Drive Motor Fault, ZAPI = Open	Controller Dependent	Check connections to the motors. Cycle power to the lift and if that does not resolve the issue, replace the Motor Controller.
78	Pump Motor Short Fault or Wrong Pump Speed Input	Disable Lifting and Driving	Check connections to the pump motor. Cycle power to the lift and if that does not resolve the issue, replace the Motor Controller.
79	Left Drive Motor Short Fault	Disable Lifting and Driving	Check the Motor connections and make sure they are tight. Check the Motor for a short.
80	Over 80% Load Warning	Warning Only	Platform is getting close to its limit of weight. Consider not adding more load.
81	Right Drive Motor Short Fault	Disable Lifting and Driving	Check the Motor connections and make sure they are tight. Check the Motor for a short.
82	Right Brake Coil Fault	Disable Lifting and Driving	Check the connections to the Coil's terminals and make sure they are tight. If so, check the coil itself to see if it is open or shorted.
83	Left Brake Coil Open or Short Fault	Disable Lifting and Driving	Check the connections to the Coil's terminals and make sure they are tight. If so, check the coil itself to see if it is open or shorted.
85	Brake Release Switch is on when powering up in normal mode	Disable All Motion	Turn the switch off before powering up in normal mode or look for shorts to ground in signal 5B of the ECU.
86	Platform is Elevated when trying to go into Brake Release mode	Disable All Motion	Return the platform to the stowed position before attempting to enter brake release or check connections of the Bottom Limit switch against the wiring diagram for the 2356 with ZAPI.
87	Brake Release Switch is not on when trying to go into Brake Release mode.	Disable All Motion	Turn the Brake Release Switch on first or check connections to the switch.
89	Motor Controller, Motor Field Open (Triplat only)	Disable Lifting and Driving	One of the Sepex Motor Field windings may be open. Consider replacing the motor.
90	Over 90% Load Warning	Warning Only	Platform is getting close to its limit of weight. Consider not adding more load.
91	Motor Controller, Left Motor Field Short (Triplat only)	Disable Lifting and Driving	The left Sepex motor field windings may be shorted. Consider replacing the motor.
92	Motor Controller, Right Motor Field Short (Triplat only)	Disable Lifting and Driving	The right Sepex motor field windings may be shorted. Consider replacing the motor.

99	Over 99% Load Warning	Warning Only	Platform has reached its limit of weight. Do not add more load.
OL	Overloaded Platform Fault	Disables All Motion	Remove the excess load immediately.
BR	Brake Release mode has been successfully entered. (All Electric Drive Lifts)	Disable Lifting and Driving. Lift can be manually pushed.	If B.R. mode is not desired, cycle power to the lift.
LL	Machine Tilted Beyond Safe Limits Fault	Disable Lifting and Driving	If the machine is tilted, find a way to make it level. If the machine is level, check the wiring to the tilt sensor and then the sensor itself.

